



# Electro-Voice<sup>®</sup> THE DELTAMAX<sup>™</sup> SYSTEM

## OWNER'S MANUAL



**DMC 1122B CONTROLLER  
DML-1122A LOUDSPEAKER**

**TABLE OF CONTENTS**

|   | PAGE |
|---|------|
| <b>DESCRIPTION AND FEATURES</b> .....     | 1    |
| <b>SPECIFICATIONS</b> .....               | 2    |
| <b>BLOCK DIAGRAM</b> .....                | 7    |
| <b>OPERATION</b>                          |      |
| Front Panel Indicators and Controls ..... | 8    |
| Back Panel Connections .....              | 9    |
| Typical System Operation .....            | 10   |
| <b>AMPLIFIER/CONTROLLER CALIBRATION</b>   |      |
| Amplifier Calibration Procedure .....     | 12   |
| Controller Calibration Procedure .....    | 12   |
| <b>INSTALLATION</b>                       |      |
| Amplifier Requirements .....              | 13   |
| Connector and Cable Requirements .....    | 13   |
| Controller Connections .....              | 13   |
| Loudspeaker Connections .....             | 14   |
| Multiple Loudspeaker Arrays .....         | 14   |
| Speaker Installation .....                | 15   |
| Controller Installation .....             | 16   |
| Power Source .....                        | 16   |
| Mounting .....                            | 17   |
| Grounding .....                           | 17   |
| Ventilation .....                         | 17   |
| Security .....                            | 17   |
| Maintenance .....                         | 17   |
| <b>ASSEMBLY VIEW OF P.C. BOARDS</b>       |      |
| Power Supply Board .....                  | 20   |
| Main Board .....                          | 21   |
| <b>SCHEMATIC DIAGRAMS</b> .....           | 22   |
| <b>SERVICE/WARRANTY INFORMATION</b>       |      |
| Shipping Damage .....                     | 28   |
| Field Service .....                       | 28   |
| Controller Power Inspection .....         | 28   |
| Driver Replacement .....                  | 28   |
| Warranty .....                            | 28   |
| <b>REPAIR PARTS LIST</b> .....            | 29   |

**WARNING: TO REDUCE THE RISK OF FIRE OR ELECTRIC SHOCK,  
DO NOT EXPOSE THIS EQUIPMENT TO RAIN OR MOISTURE.**

**DESCRIPTION****GENERAL**

The DeltaMax™ DMC-1122B/DML-1122A system consists of a two-way biamped, high-performance speaker system and a companion electronic controller. The DML-1122A is a full-range loudspeaker system intended for high-level sound reinforcement in touring-sound and permanent-installation applications. The trapezoidal cabinet shape allows tight cluster designs, enabling maximum mutual coupling and single-point-source arrays. The unique circuitry of the DMC controller provides accurate protection for the loudspeakers without the use of shifting high-pass or low-pass filters, shifting crossover frequencies or independent band-pass compression. The electronic protection is invoked only when catastrophic conditions are present for the loudspeakers. The result is that accurate frequency response is maintained from the lowest sound pressure levels to the very highest sound pressure levels available from the loudspeakers.

There are two models in the DML-1122A series: the DML-1122AP (painted finish) and the DML-1122APF (painted finish with flying hardware).

The DML-1122A utilizes a 12-inch woofer and a 1.3-inch-exit modified DH1A high-frequency driver. The system uses flat-front, constant-directivity, high-frequency horns which are based on the Electro-Voice HP series (Patent #4,685,532) and are geometrically optimized for performance from 1,250 Hz to 20,000 Hz.

The DeltaMax™ flying version model DML-1122APF includes three steel-reinforced aircraft-type pan fittings on the top and bottom of the enclosures to facilitate the hanging of multi-cabinet arrays. Each DeltaMax™ flying system is packed with a separate owner's manual which provides specific hanging instructions.

The electronic circuits are designed to provide optimum audio performance, even when the audio drive level is increased for maximum loudness. Precise speaker modeling circuits control a high-performance compressor and voltage limiter which provide speaker excursion protection, voice-coil temperature protection, and amplifier maximum-power limiting.

Where very high levels of deep bass are required, the DMC-2181S/DML-2181A DeltaMax™ sub-woofer system may be added to the DMC-1122B/DML-1122A. The DML-2181A loudspeaker cabinet, with two manifolded eighteen-inch speakers, and the DMC-2181 series electronic controllers

were designed specifically to work in conjunction with the two-way systems to provide extremely high-level low-frequency output down to 35 Hz.

Optimum performance of these speakers can only be assured when used with their dedicated electronics. **Do not use with other electronic crossovers and/or processors.**

**FEATURE SUMMARY**

- Fourth-order Linkwitz-Riley crossover filters provide smooth, accurate response through the crossover region.
- Special equalization circuits allow flat, wideband system response.
- Sensing circuits for the drivers control the compressor and voltage limiter to prevent voice-coil overheating, overexcursion and amplifier clipping without affecting spectral balance or program dynamics.
- Dual-time constant compressor circuit with variable compression ratio reduces peak and average levels for loudspeaker thermal protection and amplifier clipping prevention as necessary while preserving relative program dynamics.
- Voltage-clamp loudspeaker excursion protection does not alter overall program dynamics or frequency response.
- A connection to the control voltage is available through a jack on the back panel. This allows precise gain tracking when more than one unit is used.
- The front panel display shows drive signal level and compressor gain reduction. Sensing display for each sense channel shows amplifier limit, excursion limit, and temperature limit. When its limit is approached, each LED lights yellow.
- Speaker system is trapezoidal for compact arrays. Flying versions feature integral, steel-reinforced fittings to facilitate hanging.
- Both the woofer and the compression driver employ the best available technology for high power and accurate sound reproduction.
- A state-of-the-art, flat-front, constant-directivity horn is utilized for even coverage and flat response.

| CONTROLLER SPECIFICATIONS   |   |
|---|---|
| <p><b>CHANNEL CONFIGURATIONS:</b><br/>Monoaural two-way; two sense channels</p> <p><b>FILTER TYPE:</b><br/>4th-order Linkwitz-Riley</p> <p><b>CROSSOVER FREQUENCY:</b><br/>1,250 Hz</p> <p><b>GAIN:</b><br/>5 dB nominal</p> <p><b>SIGNAL-PATH EQUALIZATION (see Figure 1),</b><br/><b>LF EQ:</b><br/>-3 dB at 40 Hz, +11 dB at 84 Hz<br/><b>LF Signal Delay:</b><br/>0.03 ms at crossover frequency<br/><b>HF EQ:</b><br/>4th order optimized for DML-1122A series driver and horn</p> <p><b>TOTAL HARMONIC DISTORTION, 20 - 20,000 Hz:</b><br/>0.03% typical, 0.1% maximum</p> <p><b>NOISE, EACH OUTPUT, 20 - 20,000 Hz NBW, TYPICAL:</b><br/>-86 dBu</p> <p><b>SIGNAL INPUT,</b><br/><b>Type:</b><br/>Electronically balanced differential<br/><b>Maximum Level:</b><br/>+18 dBu<br/><b>Impedance:</b><br/>27,000 ohms and .0015μf<br/><b>CMRR, Typical:</b><br/>-55 dB</p>  | <p><b>Connector:</b><br/>Female 3-pin XLR-type</p> <p><b>SENSE CHANNEL INPUTS,</b><br/><b>Type:</b><br/>Floating differential<br/><b>Maximum Level,</b><br/><b>LF:</b> 145 V rms<br/><b>HF:</b> 145 V rms<br/><b>Impedance:</b><br/>100 kilohms each side to ground<br/><b>Connector:</b><br/>Two five-way binding posts</p> <p><b>OUTPUTS (LF and HF):</b><br/><b>Type:</b><br/>Transformer floating differential<br/><b>Maximum Level:</b><br/>+18 dBu<br/><b>Minimum Load Impedance for Full Level:</b><br/>600 ohms<br/><b>Connectors:</b><br/>Male 3-pin XLR-type</p> <p><b>POWER REQUIREMENTS:</b><br/>100, 120, 220, 240 V ac, 50 - 60 Hz, 13 W</p> <p><b>CHASSIS CONSTRUCTION:</b><br/>Painted steel</p> <p><b>COLORS:</b><br/>Gray front panel/black chassis with white graphics</p> <p><b>MOUNTING:</b><br/>EIA 19-inch rack mount, 1.75 in. high, 8.97 in. behind panel (including connectors); supplied with front-panel security cover for controls.</p> |
| SYSTEM SPECIFICATIONS   |   |
| <p><b>Frequency Response, Measured in Farfield, Calculated to One Meter on Axis, Swept One-Third-Octave Pink Noise, One Watt into LF Midband (2.83 V at 250 Hz), Anechoic environment, ±3 dB (see Figure 2):</b><br/>67-20,000 Hz</p> <p><b>Sound Pressure Level at One Meter, One Watt Input Power, Anechoic Environment, Band-Limited Pink-Noise Signal,</b><br/><b>High Frequency:</b><br/>110 dB<br/><b>Low Frequency:</b><br/>98 dB</p> <p><b>Typical System Maximum Continuous Sound Pressure Levels at One Meter, Anechoic Environment:</b><br/>123 dB</p> <p><b>Typical System Maximum Peak Sound Pressure Levels at One Meter, Anechoic Environment:</b><br/>129 dB</p> <p><b>Crossover Frequency:</b><br/>1,250 Hz</p> <p><b>Beamwidth Angle Included by 6-dB-Down Points on Polar Responses, Indicated One-Third-Octave Bands of Pink Noise (see Figure 4),</b><br/><b>1.0-20 kHz Horizontal:</b><br/>80° (+25°, -20°)</p> | <p><b>3.8-20 kHz Vertical:</b><br/>55° (+25°, -5°)</p> <p><b>Directivity Factor <math>R_0</math> (Q) 1.0-20 kHz Median (see Figure 5):</b><br/>10.6 (+9.3, -4.0)</p> <p><b>Directivity Index <math>D_0</math>, 1.0-20 kHz Median (see Figure 5):</b><br/>9.8 dB (+3.2 dB, -1.6 dB)</p> <p><b>Distortion, 115 dB SPL at One Meter, Shaped Spectrum (see Figure 6),</b><br/><b>Second Harmonic</b><br/><b>100 Hz:</b><br/>4.5%<br/><b>800 Hz:</b><br/>0.8%<br/><b>2,000 Hz:</b><br/>0.7%<br/><b>5,000 Hz:</b><br/>1.6%</p> <p><b>Third Harmonic</b><br/><b>100 Hz:</b><br/>0.9%<br/><b>800 Hz:</b><br/>1.8%<br/><b>2,000 Hz:</b><br/>0.9%<br/><b>5,000 Hz:</b><br/>1.6%</p>   |

**SPEAKER SPECIFICATIONS**

**Transducer Complement,**  
**High Frequency:**  
 DH1A variant compression driver (1.3-inch exit)  
**Low Frequency:**  
 DL12X variant 12-inch woofer

**Efficiency,**  
**High Frequency:**  
 25%  
**Low Frequency:**  
 4.5%

**Long-Term Average Power Handling Capacity,**  
**High Frequency (per AES2-1984):**  
 75 watts  
**Low Frequency (per EIA RS-426A):**  
 300 watts

**Short-Term Power Handling Capacity,**  
**High Frequency:**  
 300 watts  
**Low Frequency:**  
 1,200 watts

**Maximum Long-Term Midband Acoustic Output,**  
**High Frequency:**  
 18.8 watts  
**Low Frequency:**  
 13.5 watts

**Nominal Impedance,**  
**High Frequency:**  
 8 ohms

**Low Frequency:**  
 8 ohms

**Minimum Impedance,**  
**High Frequency:**  
 6.0 ohms  
**Low Frequency:**  
 8.4 ohms

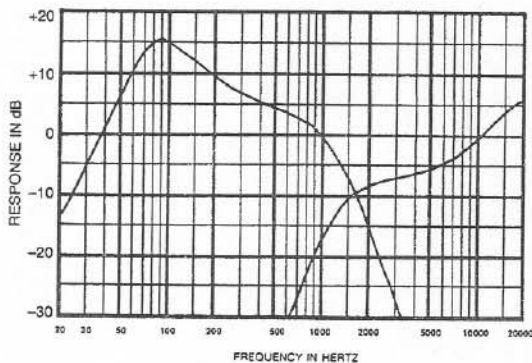
**Dimensions,**  
**Height:**  
 58.4 cm (23.0 in.)  
**Width:**  
 37.1 cm (14.63 in.)  
**Depth:**  
 35.6 cm (14.0 in.)

**Net Weight:**  
 30.7 kg (68 lb)

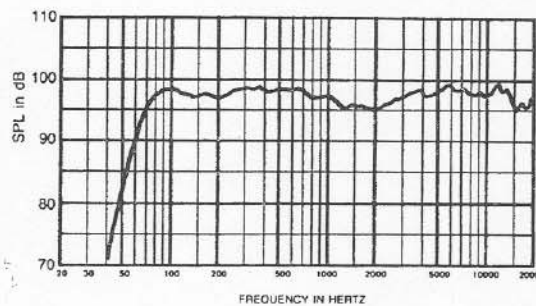
**Shipping Weight:**  
 33.9 kg (75 lb)

**Enclosure Materials,**  
**Structural:**  
 3/4-inch 14-ply birch plywood  
**Finish:**  
 Black textured paint  
**Grille:**  
 Steel with charcoal-gray foam

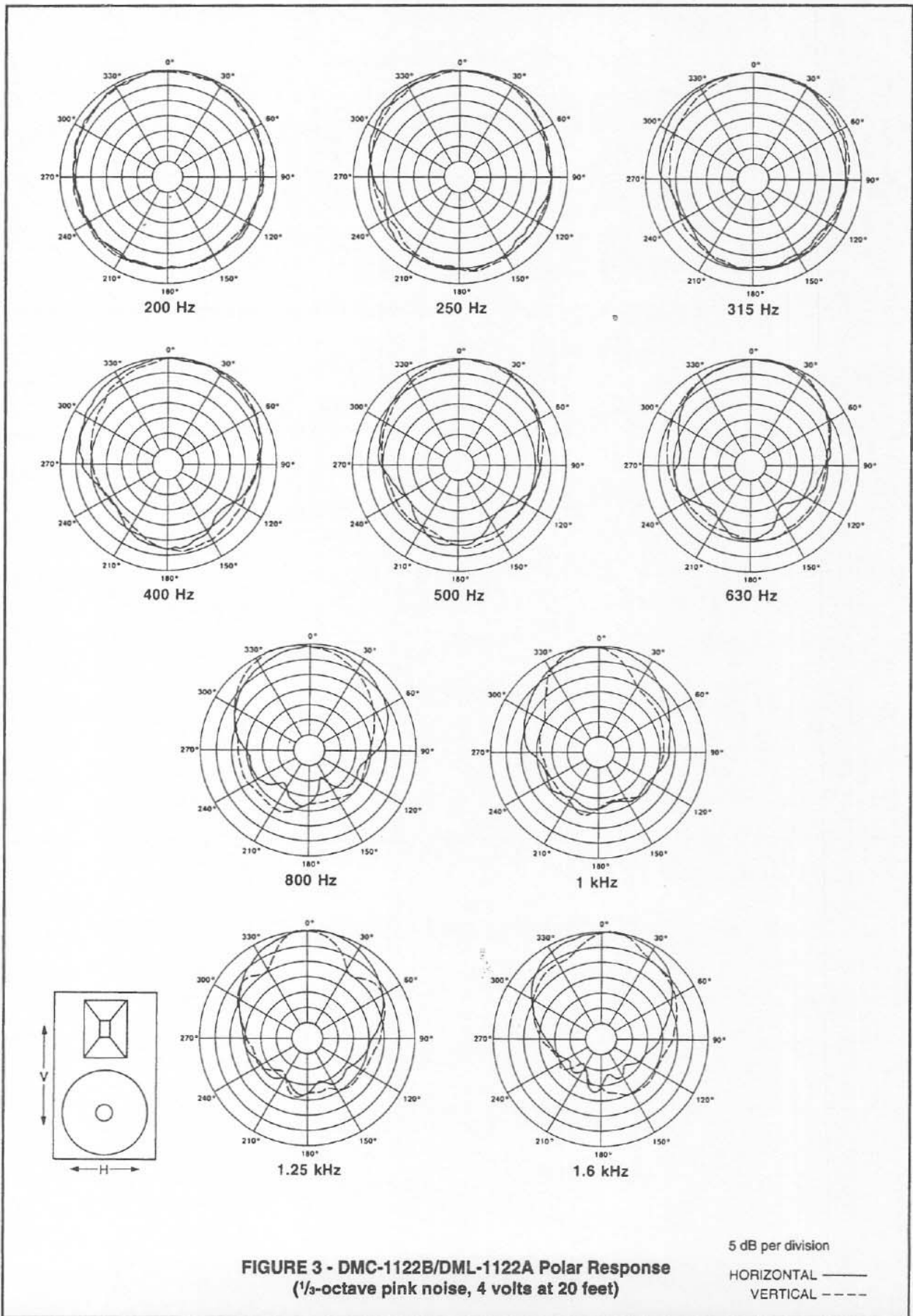
**Hanging (DML-1122APF only):**  
 3-point flying system (accepts Aeroquip 32326 and 32343 fittings)



**FIGURE 1 - DMC-1122B Frequency Response**



**FIGURE 2 - DMC-1122B/DML-1122A  
 Axial Frequency Response  
 (1 watt/1 meter into LF midband)**



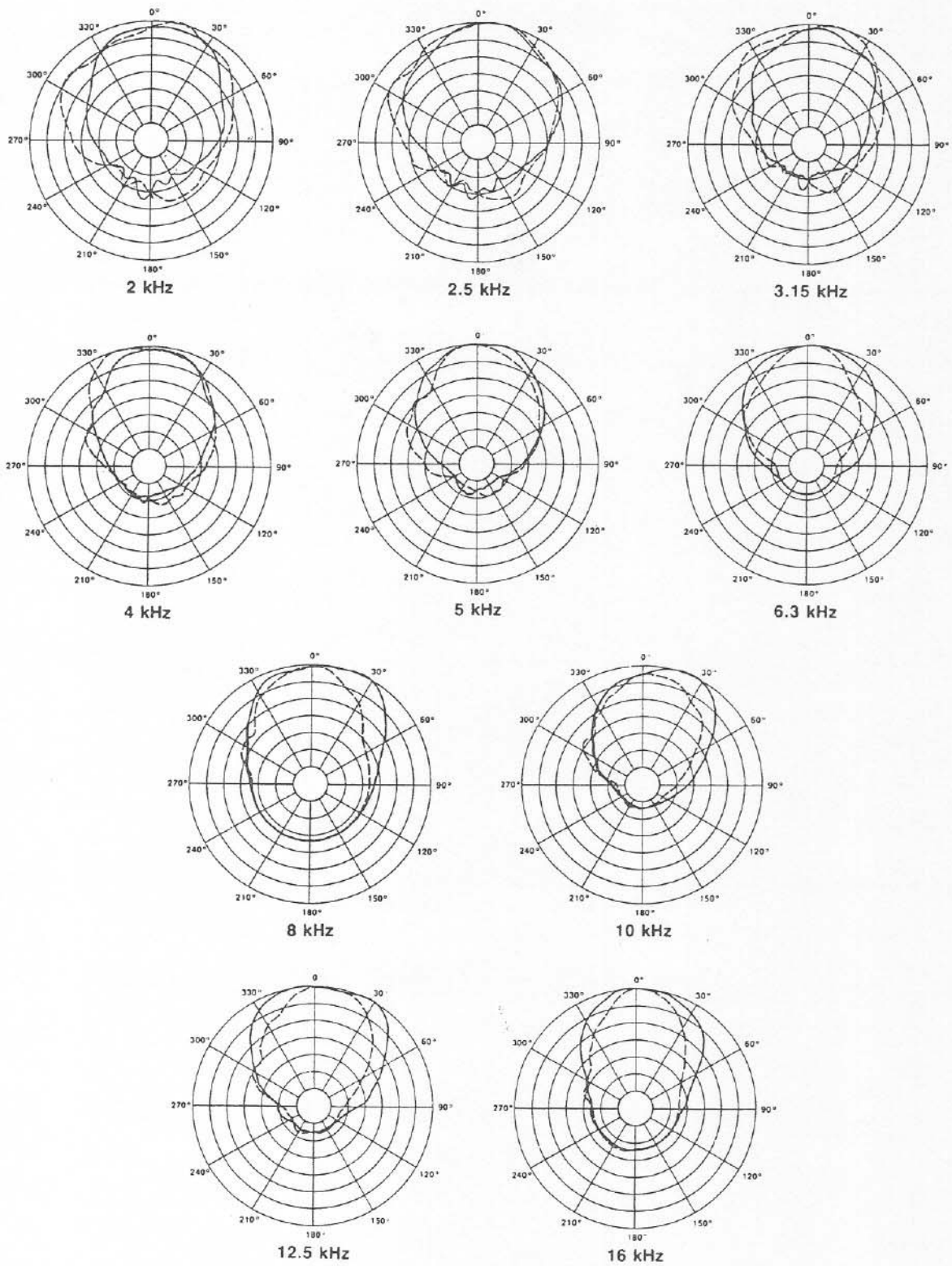
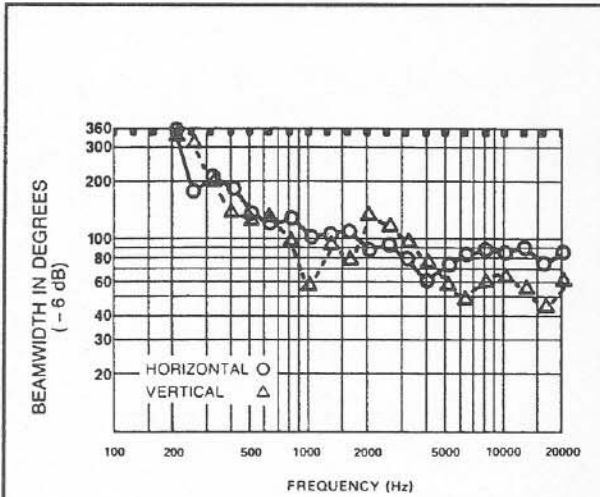
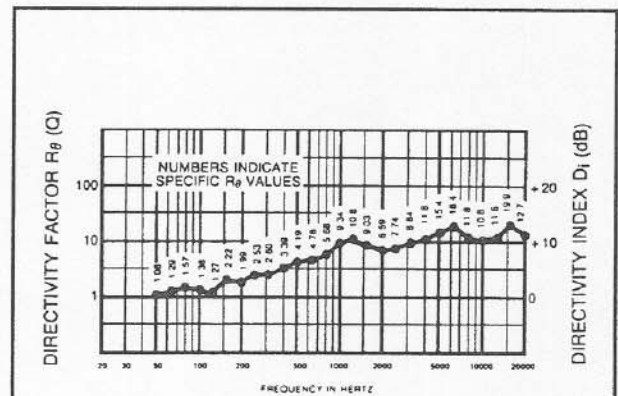


FIGURE 3 (continued) - DMC-1122B/DML-1122A Polar Response  
 (1/3-octave pink noise, 4 volts at 20 feet)

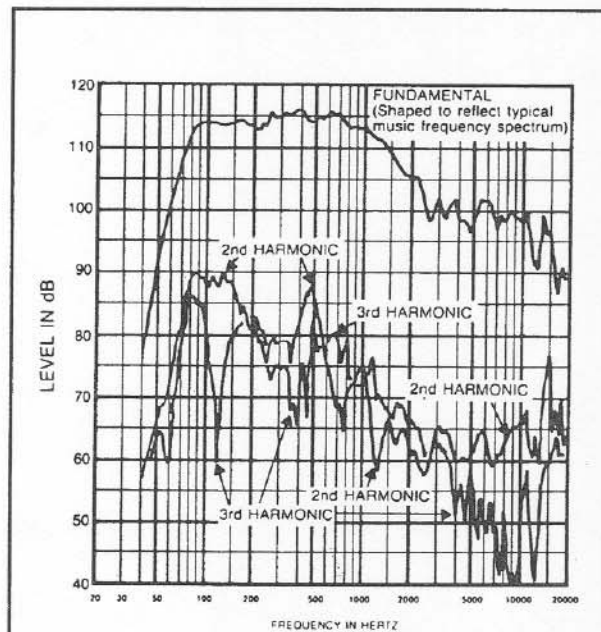
5 dB per division  
 HORIZONTAL ———  
 VERTICAL - - - -



**FIGURE 4 - DMC-1122B/DML-1122A**  
 Beamwidth vs. Frequency Whole Space  
 (anechoic)



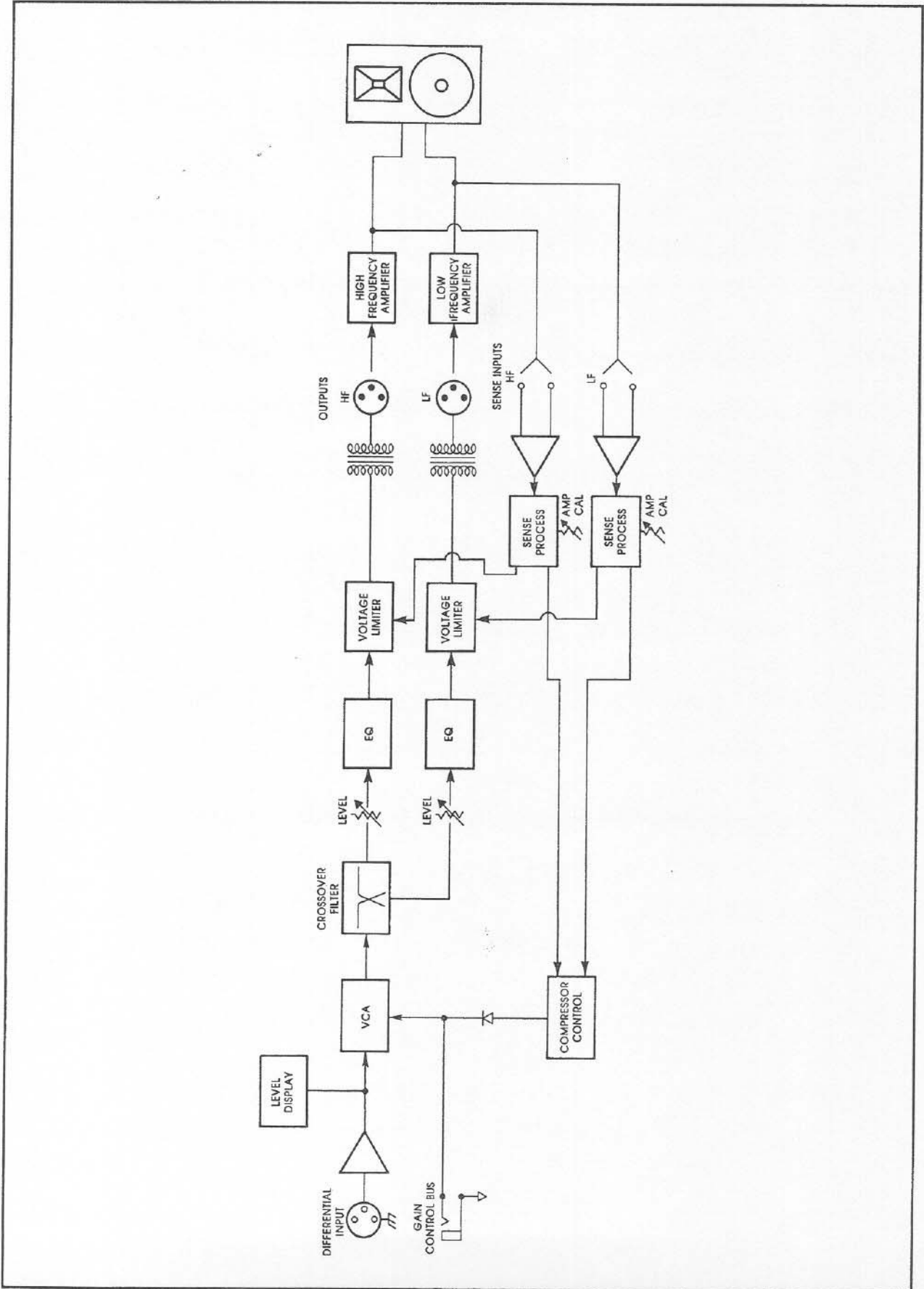
**FIGURE 5 - DMC-1122B/DML-1122A**  
 Directivity Factor and Directivity Index  
 vs. Frequency Whole Space (anechoic)

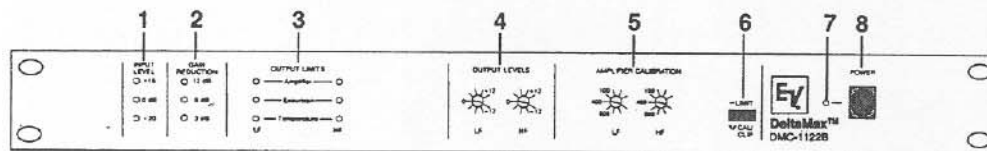


**FIGURE 6 - DMC-1122B/DML-1122A**  
 Harmonic Distortion  
 (115 dB SPL/1 meter using typical  
 music frequency spectrum)



FUNCTIONAL BLOCK DIAGRAM





PICTORIAL 1 — DMC-1122B Front Panel Diagram

## OPERATION

### FRONT PANEL INDICATORS AND CONTROLS (refer to pictorial 1)

1. **INPUT LEVEL INDICATORS:** Three LEDs show the drive level at the input of the controller. Levels are calibrated in dBu (-20, 0, +16)

**NOTE:** Do not allow the 16-dB input-level indicator to stay on continuously. If the 16-dB indicator is allowed to stay on for long periods, the input circuit will clip. The input signal should be reduced until the 16-dB indicator lights only on loud instantaneous peaks.

2. **GAIN REDUCTION INDICATORS:** Three LEDs show how much gain reduction is occurring in the compressor at the input of the controller. The display is calibrated in relative dB (3, 6, 12). Gain reduction occurs only when the maximum temperature, excursion and amplifier capabilities are exceeded for either the woofer or compression driver. The Output-Limits display indicates which limits are being exceeded when gain reduction occurs.

**NOTE:** Do not allow the 12-dB-gain reduction indicator to stay on continuously. If the 12-dB indicator is allowed to stay on for long periods, the speaker may be damaged. The input signal should be reduced until the 12-dB indicator lights only on loud passages.

3. **OUTPUT LIMIT INDICATORS:**

- A. **TEMPERATURE LIMIT:** These LED's light when the temperatures of the woofer or compression-driver voice coils approach their maximum allowable limit. Under this condition, gain reduction will occur at the input of the controller so that the maximum-temperature limits will not be exceeded for either the woofer or compression driver.

- B. **EXCURSION LIMIT:** These LED's light when the excursion of the woofer cone or compression-driver diaphragm approach their maximum allowable limit. Under this condition, voltage clamping will occur at the output of either the low- or high-frequency section so that the maximum-excursion limits will not be exceeded for either the woofer or compression driver.

- C. **AMPLIFIER LIMIT:** These LED's will provide status information for the high- and low-frequency power amplifiers if the controller has been calibrated to the amplifiers. (See the AMPLIFIER/CONTROLLER CALIBRATION section.) With the Cal/Clip-Limit switch pressed in, the LED's will signal the occurrence of amplifier clipping. With the switch in the outward position, the LED's indicate that gain reduction in the form of hard limiting is occurring at the input of the controller to prevent the amplifiers from clipping.

4. **OUTPUT LEVEL CONTROLS:**

- A. **LF:** This control adjusts the level of the low-frequency output signal. The control range is from -12 dB to +12 dB.

**NOTE:** The gain has been structured within the DMC-1122B controllers so that DML-1122A loudspeaker will have a flat frequency response (as shown in Figure 2) in an anechoic environment with the output levels of the controllers set in the 0-dB-detent position and with the amplifier channels having identical gain driving the LF and HF sections of the speaker.

**OPERATION (continued)****5. AMPLIFIER CALIBRATION CONTROLS:**

These controls are used for calibrating the controller to both the low- and high-frequency amplifiers so that the controller can monitor the clipping of the amplifier outputs and, if desired, act as a limiter to prevent amplifier clipping. See **AMPLIFIER/CONTROLLER CALIBRATION** section.

**NOTE:** The calibrated markings on the front panel correspond to the power level that an amplifier would deliver to an 8-ohm load. A crude, approximate calibration can be obtained by rotating the control until the slot of the trimpot points at a power level equivalent to the amplifier power rating for an 8-ohm load. (When the trimpot is in its mid position it is pointing at 400 watts.)

- 6. CAL-CLIP LIMIT SWITCH:** This switch selects the mode that controller will monitor the amplifiers (assuming that the controller has been calibrated to the amplifiers - see **AMPLIFIER/CONTROLLER CALIBRATION** section). With the switch pushed in, the Amplifier Limit LED's will indicate when the amplifiers are clipping. With the switch in the outward position, the Amplifier Limit LED's will indicate that gain reduction is occurring to prevent the amplifiers from clipping.

**NOTE:** If the controller has not been calibrated to both the low- and high-frequency amplifiers, the Cal/Clip Limit switch should be pushed in. This will defeat the compressor/limiter from trying to prevent amplifier clipping. (The Amplifier Limit LED's will still flash when the amplifier exceeds the power levels that the Amplifier Calibration trimpots are set to.) Poor sound quality can result with incorrect calibration and the compressor/limiter engaged.

- 7. POWER INDICATOR:** This LED lights when the controller is on.
- 8. POWER SWITCH:** This switch turns the controller on and off.

**BACK PANEL CONNECTIONS**

(refer to pictorial 2)

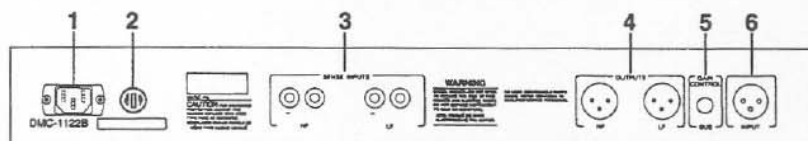
- 1. AC POWER CORD RECEPTACLE:** This receptacle is for the ac power cord (supplied with the unit).
- 2. FUSE RECEPTACLE:** This fuse receptacle requires either a 0.25 A 250 V slow blow fuse (for 100/120 V ac operation), or a 0.1 A 250 V slow blow fuse (for 220/240 V ac operation).
- 3. SENSE INPUTS:**

- A. LF:** This input is for the connection of the sense line to monitor the power delivered to the woofer and should be connected to the output of the low-frequency amplifier.
- B. HF:** This input is for the connection of the sense line to monitor the power delivered to the compression driver and should be connected to the output of the high-frequency amplifier.

**NOTE:** The Sense Inputs are floating differential with 5-way binding posts, see **CONNECTOR** and **CABLE REQUIREMENTS** section for detailed wiring information.

**4. OUTPUTS:**

- A. LF:** This input is the low-frequency output of the DMC crossover/controller and should be connected to the input of the low-frequency amplifier.
- B. HF:** This connection is the high-frequency output of the DMC crossover/controller and should be connected to the input of the high-frequency amplifier.



PICTORIAL 2 — DMC-1122B Back Panel Diagram

**OPERATION (continued)**

5. **GAIN CONTROL BUS:** This 1/4-inch jack is for slaving the gain-control busses of other DMC controllers to enable gain tracking in a multiple-controller system. See CONNECTOR and CABLE REQUIREMENTS section for detailed wiring information.
6. **INPUT:** This connection is for the full-range signal input to the DMC controller. This input is electronically balanced with a female 3-pin XLR-type connector with pin 1 as a ground reference, pin 2 high (+) and pin 3 low (-). See CONNECTOR and CABLE REQUIREMENTS section for detailed wiring information.

**TYPICAL SYSTEM OPERATION**

The DML-1122A is a full-range, biamped loudspeaker system to be used with the DMC-1122B electronic controller. Besides conventional frequency division, the DMC electronic controllers have equalization and time delay to obtain optimum performance from their respective DeltaMax™ DML loudspeaker systems. In addition, sense lines to the controllers monitor the voltage drive to each loudspeaker in the system and automatically activate protection circuitry to prevent cone/diaphragm overexcursion, voice-coil overheating and amplifier clipping. Before operating a DeltaMax™ system, the user should read this manual thoroughly and make sure that the system has been set up as detailed in the INSTALLATION section and the amplifiers and controller have been calibrated as detailed in the AMPLIFIER/CONTROLLER CALIBRATION section.

The gain and equalization structures in the DMC controllers have been set up so that the DML loudspeaker systems will have a flat frequency response (in an anechoic environment) when the Output Level trimpots on the controllers are set in the 0-dB detent position and the amplifiers all have the same gain (i.e., the amplifiers are calibrated for 32 dB of gain as detailed in the AMPLIFIER/CONTROLLER CALIBRATION section). This gives the user a standard reference every time the system is set up. Adjustments to the drive levels of the low- and high-frequency sections are then only needed to compensate for room acoustics or array configuration. When adjustments are required, they should be made with the Output Level trimpots on the controllers. The level controls on the amplifiers should be left in their calibrated positions. (See the MULTIPLE LOUDSPEAKER ARRAY section for circumstances when it is permissible to adjust the amplifier level controls.)

The input circuit of the DMC controllers clips with a + 18 dBu (6.2 volts rms) input signal. The input-signal level display has three LED's calibrated to -20, 0 and + 16 dBu. To avoid clipping, the input

should be driven only to the point that the + 16 dB LED lights on instantaneous peaks. If more gain is desired from the controller, the Output Level trimpots may be turned up. Note that there are calibrated markings on the front panel of the controller (3 dB per division) to enable accurate gain adjustments.

Extensive modeling circuits allow the controller to monitor the status of the voice-coil temperature and the cone/diaphragm excursion of the loudspeakers in each frequency band. If a loudspeaker in one of the frequency bands approaches its maximum thermal limit, a multi-time-constant compressor circuit with a variable compression ratio will reduce the peak and average levels of the full-range input signal as necessary to protect the driver, while preserving the spectral balance and the relative program dynamics. When gain reduction occurs, an Output Limit Temperature LED will light indicating which frequency-band loudspeaker is reaching its thermal limit. If a loudspeaker in one of the frequency bands approaches its maximum excursion limit, a dynamic frequency-sensitive voltage-clamping circuit at the output of that frequency band will clamp the peak of the output waveform at a level above which excursion damage would occur to the loudspeaker; hence, preserving the overall spectral balance. When voltage clamping occurs, an Output Limit Excursion LED will light indicating which frequency-band loudspeaker is reaching its excursion limit.

The DMC Controller will also prevent long-term amplifier clipping. The controller must be calibrated as detailed in the AMPLIFIER/CONTROLLER CALIBRATION section and the Cal/Clip Limit switch must be in the Out position for this function to work properly. If an amplifier in one of the frequency bands approaches clipping, a multi-time-constant compressor-limiter circuit will reduce the peak and average levels of the full-range input signal as necessary to prevent long-term clipping while preserving the overall spectral balance. When gain reduction occurs, an Output Limit Amplifier LED will light indicating which frequency-band amplifier is reaching its power limit. With the Cal/Clip Limit switch pushed in, gain reduction will not occur to prevent amplifier clipping and the Output Limit Amplifier LED's will simply indicate when the amplifiers are going into clipping.

The DeltaMax™ DMC controllers provide protection for the loudspeakers without affecting the overall spectral balance or dynamic range. The controllers have an LED display to inform the user when the protection circuitry is activated and what is causing the protection to take place. Each frequency band has three LED's to indicate loudspeaker thermal-protection activation, loudspeaker excursion protection activation and amplifier clipping (or amplifier clipping prevention). In addition, there is an LED

**OPERATION (continued)**

display to indicate the amount of long-term overall gain reduction occurring due to loudspeaker thermal protection and amplifier clipping prevention. (The instantaneous loudspeaker excursion voltage-clamping protection is not reflected in the overall gain-reduction display.)

In very high-powered applications, the detailed displays on the DMC controllers provide the user with information to make adjustments or changes to the system (if desired) to eliminate the protection and increase the acoustic output. For example:

- If an excessive amount of low-frequency protection is occurring, selective equalization can be used ( $1/3$ -octave-band equalizer, parametric equalizer, etc.) to reduce the level in the frequency range that is causing the excessive excursion, allowing the overall level to be turned up. If the desired amount of high-level low-frequency response still cannot be obtained, subwoofers (or additional subwoofers) should be added to the system.
- If an excessive amount of loudspeaker thermal protection is occurring in any frequency band, more speaker systems are generally needed. If the program material has a lot of energy concentrated in a relatively small frequency range, selective equalization may serve as an effective compromise.
- If excessive amplifier clipping (or amplifier clipping prevention) is occurring without excessive

loudspeaker thermal protection or excursion protection, larger power amplifiers should be used.

- If excessive loudspeaker thermal protection and excursion protection is occurring, more speakers should be used.
- If excessive overall gain reduction is occurring, more speakers should be added.
- If the 12-dB-gain-reduction LED is on for any significant portion of time, the level should be turned down. Levels driven beyond this point may exceed the protection capability of the protection circuitry.

When multiple controllers are used (such as in a stereo system) the control voltages should be slaved together as detailed in the INSTALLATION section. The gain of all of the controllers will then track whenever gain reduction occurs due to loudspeaker thermal protection or amplifier clipping prevention, regardless of which loudspeaker or amplifier was exceeding its limit. This will prevent acoustic image shifting at very high levels. When a DMC-2181S/DML-2181A subwoofer system is used with a full-range DeltaMax™ system (such as a DMC-1122B/DML-1122A) the control voltages should be slaved together to prevent spectral balance shifting at high levels when gain reduction occurs for loudspeaker thermal protection or amplifier clipping prevention. The loudspeaker excursion voltage-clamping protection will still operate independently in each frequency band in each controller when the control voltages are slaved.

**AMPLIFIER/CONTROLLER CALIBRATION****AMPLIFIER CALIBRATION PROCEDURE**

Maximum performance of the DeltaMax™ controller protection circuitry occurs, under the most severely over-driven conditions, when the voltage gain of the amplifiers fall in the range of 27 to 35 dB (with 32 dB being optimum). This gain range is typical of most high-power amplifiers and can easily be adjusted by simply adjusting the level controls on the amplifier.

The procedure for calibrating an amplifier to have 32 dB of gain is as follows:

1. With the amplifier turned on and without speakers hooked on the amplifier output, apply 0.5-volt rms 1,000-Hz sinewave signal to the input of the amplifier.
2. Adjust the amplifier level control until the output of the amplifier measures 20 volts rms.

**NOTE:** If the amplifier will be operated in the mono-bridged mode, it should be calibrated when wired in the mono-bridged configuration.

**CONTROLLER CALIBRATION PROCEDURE**

This procedure is for calibration of the DMC controller's internal amplifier limit circuits to the actual clip level of the power amplifiers. Calibration is set by the LF and HF Amplifier Calibration trimpots on the front panel.

Before plugging in the ac power cord, be sure the controller is wired for the correct primary (mains) voltage.

**Disconnect the speakers** and remove the security cover from the controller by removing the two screws on the front panel of the controller. Perform the following procedure:

1. Connect the controller to the low- and high-frequency power amplifier channels as detailed in the INSTALLATION section.
2. Be sure the controller LF and HF Sense Inputs are connected to the correct amplifier outputs and the **speakers are disconnected** from the amplifier.
3. Set the low- and high-frequency amplifier gain controls for 32 dB voltage gain, or as close as possible to 32 dB (this is optimum, but it can be in the range of 27 to 35 dB). See the AMPLIFIER CALIBRATION PROCEDURE section.
4. Turn the LF and HF Amplifier Calibration trimpots on the controller to full counterclockwise. Press the Cal/Clip Limit switch to its recessed Cal/Clip position with a screwdriver or other suitable tool.
5. In order to prevent thermal limiting from occurring while calibrating the amplifier limit levels, insert a shorted 1/4-inch phone plug (tip-sleeve) into the Gain control bus jack on the back of the controller. The Thermal Limit LED may still come on but no gain reduction should be indicated.
6. Send a 500-Hz sinewave test signal to the controller input.
7. Adjust the signal source level until the low-frequency amplifier begins to clip (you may turn up the LF Output Level on the controller if necessary to get the amplifier to clip). Clipping is noted by the clip indicator on the power amplifier or by monitoring the output with an oscilloscope. Now, turn the level down until the clip light just goes out (or until the clipping disappears on the oscilloscope).
8. Turn the LF Amplifier Calibration trimpot on the controller clockwise with a screwdriver until the LF Amplifier Output Limit LED comes on. Note that the slot of the trimpot is pointed at the approximate power rating of the amplifier for an 8-ohm load as denoted by the calibrated markings on the front panel of the controller. Note also that this is the maximum amount of power capable of being delivered to a single driver in this amplifier configuration.  
The LF section of the controller is now calibrated. The LF Output Level trimpot may be adjusted as necessary for the desired frequency spectrum balance without affecting calibration.
9. Change the input test signal to a frequency of 5,000 Hz.
10. Adjust the signal source level until the high-frequency amplifier begins to clip (you may turn up the HF Output Level on the controller if necessary to get the amplifier to clip). Now, turn the level down until the clip light just goes out (or until the clipping disappears on the oscilloscope).
11. Turn the HF Amplifier Calibration trimpot on the controller clockwise with a screwdriver until the HF Amplifier Output Limit LED comes on. Note that the slot of the trimpot is pointed at the approximate power rating of the amplifier for an 8-ohm load as denoted by the calibrated markings on the front panel of the controller. Note also that this is the maximum amount of power capable of being delivered to a single driver in this amplifier configuration. If the power rating of the high-frequency power amplifier is much greater than 250 watts (and, hence, the HF Amplifier Calibration trimpot on the controller is set much greater than 250 watts), then an additional margin of safety for the high-frequency driver can be obtained by setting the HF Amplifier Calibration trimpot to 250 watts.

**AMPLIFIER CALIBRATION PROCEDURE  
(continued)**

The HF section of the controller is now calibrated. The HF Output Level trimpot may be adjusted as necessary for the desired frequency spectrum balance without affecting calibration.

12. Remove the shorted 1/4-inch phone plug from the Gain Control Bus Jack and set the Cal/Clip Limit switch to the Limit position (out). Set the HF and LF Output Level controls to their center-detent position (or as desired).
13. Turn the amplifier off and connect the speaker cables to the output of the amplifier. Make certain that the "lows" are wired to the woofer and that the "highs" are wired to the compression driver. In addition, be sure to observe polarity when making speaker connections.

**NOTES:**

- A. The Amplifier Calibration trimpots may be adjusted during use with program material to set the desired amount of amplifier limiting. The limiter in the controller will allow some fast transient peaks through, allowing some amplifier clipping to occur on signal peaks after the calibration procedure. The limiter circuit will, however, prevent long-term amplifier clipping when adjusted properly.
- B. The Cal/Clip Limit switch may be left in the recessed Cal/Clip position (in) if the power amplifier has an internal limiter, or if clip protection is not desired. When left in the Cal/Clip position, the Amplifier Output Limiter indicators on the front panel of the controller will indicate when the amplifier is self-limiting or clipping.
- C. If two or more speakers are connected in parallel to an amplifier output, most amplifiers will exhibit a drop in clipping voltage due to the lower load impedance. This will require that the Amplifier Calibration trimpot be set to a value slightly lower than the value obtained in the "no-load" calibration test.

Note that the result of this is that, even when multiple speakers are paralleled on an amplifier channel, the Amplifier Calibration trimpot will always end up pointing at the maximum amount of power (on the calibrated markings on the front panel) that the amplifier is capable of delivering to each individual driver no matter how many drivers are connected in parallel.

- D. Do not change the amplifier gain, or recalibration will be necessary. Use the LF and HF Output Level controls on the controller to change power amplifier drive levels. The Output Level controls do not affect controller calibration.

**INSTALLATION****AMPLIFIER REQUIREMENTS**

Professional power amplifiers with the following ratings are recommended for use with the DMC-1122B/DML-1122A system:

**LF:** 300-600 watts continuous into eight ohms

**HF:** 125-250 watts continuous into eight ohms

The use of amplifiers with lower power ratings is acceptable, however, the full-power capabilities of the DML speakers will not be realized. The use of amplifiers with significantly higher power ratings is wasteful and may endanger the loudspeakers; it is generally not recommended.

Under certain circumstances, however, higher rated power amplifiers are acceptable. It is acceptable to drive the DML-1122A speaker with a stereo power amplifier having the recommended LF power rating utilizing one channel to drive the low frequencies and the other channel to drive the high frequencies. For an extra degree of protection when operating in this configuration, the user may want to set the HF Amplifier Calibration level to the 250-watt position to limit excessively high power levels from reaching the compression driver.

DML-1122A speakers may be paralleled with other DML-1122A speakers if the amplifier is capable of delivering adequate power to each speaker at the lower impedance. Under no circumstances should DML-1122A and DML-1152A speakers be paralleled on the same amplifier channels.

**NOTE:** For proper operation of the protection circuitry, the power amplifiers must be calibrated to have a voltage gain between 27 and 35 dB (32 dB is optimum). See the AMPLIFIER/CONTROLLER CALIBRATION section.

**CONNECTOR AND CABLE REQUIREMENTS****Controller Connections**

The DeltaMax™ controllers have 3-pin XLR-type connectors for signal input and output. The input is electronically balanced and has a female connector with pin 1 as a referenced ground, pin 2 high (+) and pin 3 low (-). The outputs are transformer balanced and have male connectors with pin assignments identical to the input. Figure 13 illustrates the preferred interconnection between the controller and the power amplifier. When driving unbalanced lines, pin 3 should be shorted to ground.

**INSTALLATION (continued)**

To hook up the DeltaMax™ controller to the power amplifiers, connect the LF Output of the controller to the input of the low-frequency amplifier and the HF Output of the controller to the input of the high-frequency amplifier. The outputs of the low- and high-frequency amplifiers are then connected to the LF input (woofer) and HF input (compression driver) respectively, of the DML-1122A speaker system. See the LOUDSPEAKER CONNECTIONS section for details of the loudspeaker wiring. See Figures 8 and 9 for two typical system configurations.

Sense lines must be connected to the DeltaMax™ controller so that the power levels being delivered to the woofer and compression driver can be monitored. This is accomplished by connecting the output of the low-frequency amplifier to the LF Sense Input on the controller and the output of the high-frequency amplifier to the HF Sense Input on the controller. The sense input connectors are 5-way binding posts wired in a floating differential configuration. This configuration makes it possible to connect sense lines to a bridged amplifier without shorting out one of the legs of the amplifier. High-quality banana plugs may be used for these connections, but wires underneath the binding posts provide greater security. Small gauge wire (e.g. 22 gauge) is acceptable for these connections because there is minute current flow, but be sure the connections are secure and safe enough for the high voltages from the amplifier output.

The gain control bus in the DMC controllers is accessible through a two-conductor 1/4-inch jack on the back of the controller. This feature is used when it is desired for the gain of two or more units to track. Using a standard 1/4-inch patch cable, connect the jacks together. For more than two units, use Y-connectors. For example:

1. When multiple controllers and loudspeakers are used (such as in a stereo system), the controller's Gain Control jacks should be connected together to maintain level balancing and imaging.
2. When the DMC-1122B/DML-1122A full-range system is used with the DMC-2181S/DML-2181A subwoofer system, the controller's Gain Control jacks should be connected together between the two controllers to ensure flat-frequency response when the controllers are operating in the protection mode.

**Loudspeaker Connections**

The DML-1122A speaker system is equipped with 4-pin Neutrik Speakon™ NL4MPR connectors for electrical connection to the woofer and compression drivers. Each cabinet has two identical connectors with parallel wiring for connecting additional DML speaker systems. One mating Neutrik

Speakon™ NL4FC cable-end connector is supplied with each system.

Cables, connectors and wiring accessories are available for the DML speaker systems from Pro Co. Sound, Inc. and Whirlwind Music Distributors, Inc. To find your local Pro Co., Whirlwind or Neutrik dealer, contact:

Pro Co Sound, Inc.  
135 E. Kalamazoo Ave.  
Kalamazoo, MI 49007

Whirlwind Music Distributors, Inc.  
P.O. Box 1075  
Rochester, NY 14603

Neutrik USA, Inc.  
195-S3 Lehigh Ave.  
Lakewood, NJ 08701

The pin connections are as follows:

- Pin 1 - = LF (-)
- Pin 1 + = LF (+)
- Pin 2 - = HF (-)
- Pin 2 + = HF (+)

Both the low-frequency and high-frequency inputs present a nominal eight-ohm load to the amplifier; however, the compression driver has a low-frequency protection capacitor in series.

**Multiple Loudspeaker Arrays**

Arrays consisting of multiples of identical DeltaMax™ loudspeaker systems can be implemented in a variety of ways. There does not need to be one controller for every speaker cabinet. Generally, there only needs to be as many controllers as there are different program sources. For example; a monaural program source requires one DMC-1122B controller; a stereo program source requires two DMC-1122B controllers; etc. In addition, a DMC-2181S/DML-2181A subwoofer system may be added to a DMC-1122B/DML-1122A system. The DMC-2181S is a stereo controller with left and right high outputs (above 100 Hz) and a mono-summed sub output (below 100 Hz). A monaural program source requires one DMC-2181S controller and one DMC-1122B controller; a stereo program source requires one DMC-2181S controller and two DMC-1122B controllers.

For the sake of simplicity, the following discussion will be confined to the various possible connection schemes for arrays of identical loudspeakers with only one program source and without subwoofers. (A stereo array can be broken down and analyzed as two separate arrays, each having a separate program source. Subwoofer wiring is addressed in the DMC-2181S manual.) Amplifier inputs, outputs and sense lines will be addressed in the discussion.

The outputs (SUB OUT, LF OUT, HF OUT, etc.) of the DMC controllers are connected to the inputs of multiple amplifier channels through the use of Y-



**INSTALLATION (continued)**

cords (or multiple Y-cords). The number of amplifier channels that can be driven by a single output of a controller is limited only by the total combined input impedance of the paralleled amplifiers. The DeltaMax™ controller outputs can drive a combined impedance of 600 ohms or greater. (For example, sixteen amplifiers, each having an input impedance of 10 k ohms, can be paralleled off of one DMC output.) If it is necessary to parallel additional amplifiers, line-level distribution amplifiers will have to be employed to drive the amplifier inputs. (Alternatively, multiple DMC controllers with paralleled inputs could be used to distribute the amplifier load.)

For the case where all of the DeltaMax™ loudspeakers are paralleled on the output of a single amplifier channel and only one controller is used, the sense line to that controller is connected to the output of the amplifier. In this case, all of the loudspeakers are driven at the same level and the controller monitors the voltage drive to each speaker. Make sure that the amplifier is calibrated for 32 dB of gain and that the controller is calibrated to the amplifier (see AMPLIFIER/CONTROLLER CALIBRATION section).

For the case where the Delta Max™ loudspeakers are powered by multiple amplifiers, all driven at the same level and only one controller is used, the sense line to that controller is connected to any one of the amplifier outputs. Note that this requires the use of identical amplifiers, each calibrated for 32 dB of gain and that the controller is calibrated to the amplifiers (see AMPLIFIER/CONTROLLER CALIBRATION section). Although the controller is only actually sensing one amplifier and one set of loudspeakers, they all are being protected equally as long as all of the amplifiers are performing identically.

For the case where the DeltaMax™ loudspeakers are powered by multiple amplifiers, each driven at different levels and only one controller is used, the sense line to that controller is connected to the output of the amplifier that is delivering the highest power levels to the loudspeakers. This is a fairly common occurrence; where the levels of individual loudspeakers in an array are adjusted to provide even room coverage. In this case, the amplifier being sensed must be calibrated for 32 dB of gain and the controller is calibrated to that amplifier. (See AMPLIFIER/CONTROLLER CALIBRATION section.) The other amplifiers must be identical to the one being sensed, with the exception that their levels are turned down as necessary to obtain even room coverage. Although the controller is actually sensing only one amplifier and one set of loudspeakers, they are all being protected because the one being driven the hardest is triggering the protection.

Note in the last two examples where multiple amplifiers are used to power multiple loudspeakers in an array, the level setting and calibration of the amplifiers are critical to ensure that all of the loudspeakers are protected with only one sense line. If, in the normal course of operation the level settings of the amplifiers are likely to be tampered with, the system should be set up with one controller per amplifier, allowing each set of speakers to be monitored. In this case, each amplifier would be calibrated for 32 dB of gain and any level adjustment of loudspeakers would be done with the Output Level trimpots on the controllers.

It should be noted that, when multiple DML-1122A loudspeaker systems are closely assembled in an array, a build up of low and lower-mid frequencies can occur. The cause of this phenomenon is twofold. Mutual acoustic coupling between woofers at the lowest frequencies (typically below 100 Hz) results in increased efficiency and, hence, increased sound pressure level. (A similar effect occurs when a loudspeaker is placed near a boundary—a wall, a ceiling, a floor, etc.) In the upper-bass/lower-mid-range region (typically below 500 Hz), an array of multiple woofers will have greater directivity (a higher Q) than that of a single woofer, resulting in higher on-axis sound pressure levels. Because the equalization of the DMC-1122B controller is tailored to provide a flat acoustic frequency response with a single DML-1122A loudspeaker, an over emphasis of the low and lower-mid frequencies can result when multiple loudspeakers are assembled together. The exact nature of this phenomenon will depend on the details of the array (the number of loudspeakers, their spacing, the splay angles, proximity to boundaries, etc.) An increase in acoustic response at these frequencies can result in low-frequency feedback or unwanted rumble, and is best dealt with using a graphic or parametric equalizer.

**SPEAKER INSTALLATION**

The DML-1122APF is a flying version of the DML-1122AP. Each cabinet has a total of six steel-reinforced aircraft-type pan fittings (three on the top and three on the bottom). This three-point flying system makes maximum use of the trapezoidal cabinets, permitting a wide range of angle adjustment and offering maximum flexibility in array design and implementation for both the touring sound company and the sound contractor. The pan fittings mate with the Aeroquip 32343 and 32326 twelve-jaw fittings. Electro-Voice offers the DMS series of rigging hardware; a complete line of flying accessories to be used with the DML speaker systems.

**INSTALLATION (continued)**

**\*\*\* CAUTION \*\*\***

The DML-1122APF speaker system should be suspended overhead only in accordance with the procedures and limitations specified in the DML-1122AF Flying Manual which is packed with each flying speaker system.

Each DML-1122A speaker system comes with four rubber feet and mounting screws as accessories for the user to install as an option if desired. Rubber feet on the enclosure lessens the possibility of slipping and sliding in applications where the speaker systems are stacked.

**CONTROLLER INSTALLATION**

**Power Source**

The DMC-1122B comes prewired from the factory for operation at 120 volts. To operate at 240 volts, the primary wiring of the power transformer must be altered.

**\*\*\* CAUTION \*\*\***

Hazardous voltages and currents may be encountered within the chassis. The service information contained within this document is for use by Electro-Voice authorized warranty stations and qualified service personnel only.

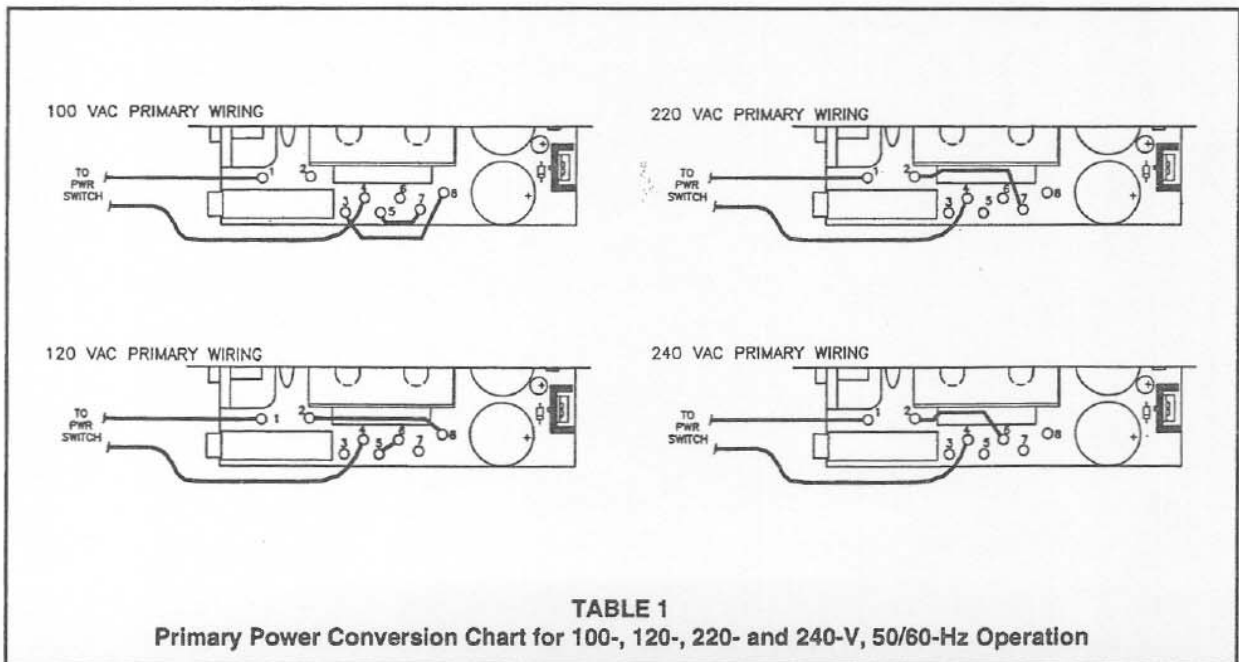
To change the transformer primary wiring configuration use the following procedure:

1. Unplug the controller's power cord from the ac power source.
2. Remove the seven screws securing the top cover. There are two screws on each side, two screws on the rear and one screw in the front panel (center, top).

3. Locate the eight voltage select solder cups near the power transformer. Referring to Table 1, reconnect the leads corresponding to the desired primary voltage.
4. Install the correct line fuse. See values in Table II.
5. Plug the power cord into an ac outlet and turn the controller on. Measure the voltage at the points shown in the PCB diagram. The measured voltage should be  $\pm 22$  volts. If the measured voltage is not within 10% of this value, turn the unit off and check the connections in step 3.
6. Reinstall the top cover with the seven screws.

| Line Voltage | Line Fuse, MDL Series Slo-Blo |
|--------------|-------------------------------|
| 100 V ac     | 0.25 A/250 V                  |
| 120 V ac     | 0.25 A/250 V                  |
| 220 V ac     | 0.10 A/250 V                  |
| 240 V ac     | 0.10 A/250 V                  |

**TABLE II**  
Main Fuse Selection Guide



**INSTALLATION (continued)****Mounting**

The unit is one rack-space high (1<sup>3</sup>/<sub>4</sub>" ) and fits a standard EIA 19-inch rack. To make wiring easier, mount the controller near the power amplifier(s).

**Grounding**

A widely accepted grounding technique for audio systems is the star connection (single-point) ground. The final configuration will be determined by the size of the system and the equipment used in the system. However, the star connection is recommended as a starting point.

The interconnecting cables of line level equipment, such as the DeltaMax™ controller should have the shields connected at one point only, usually the receiving end of the signal transmission. See Figure 8.

Never lift the third wire safety ground of the ac power cable. It protects against possible shock hazard.

When deciding how to best ground the controller in a particular system, note that the controller's input and output XLR-type connectors have pin 1 referenced to chassis ground through a 20 k resistor and a .01µF capacitor. This minimizes the possibility of a ground loop. Circuit ground ties to the chassis ground internally at one point. The input to the controller is active differential and the output is transformer isolated.

**Ventilation**

Adequate ventilation should be provided in the rack to maintain a reasonable operating temperature. The ambient temperature inside the rack cabinet should not exceed 60°C (140°F) under any conditions.

**Security**

A security cover and attachment screws are supplied to protect the control settings against uninvited adjustments.

**Maintenance**

Use a soft damp cloth to clean the unit. No other maintenance is required.

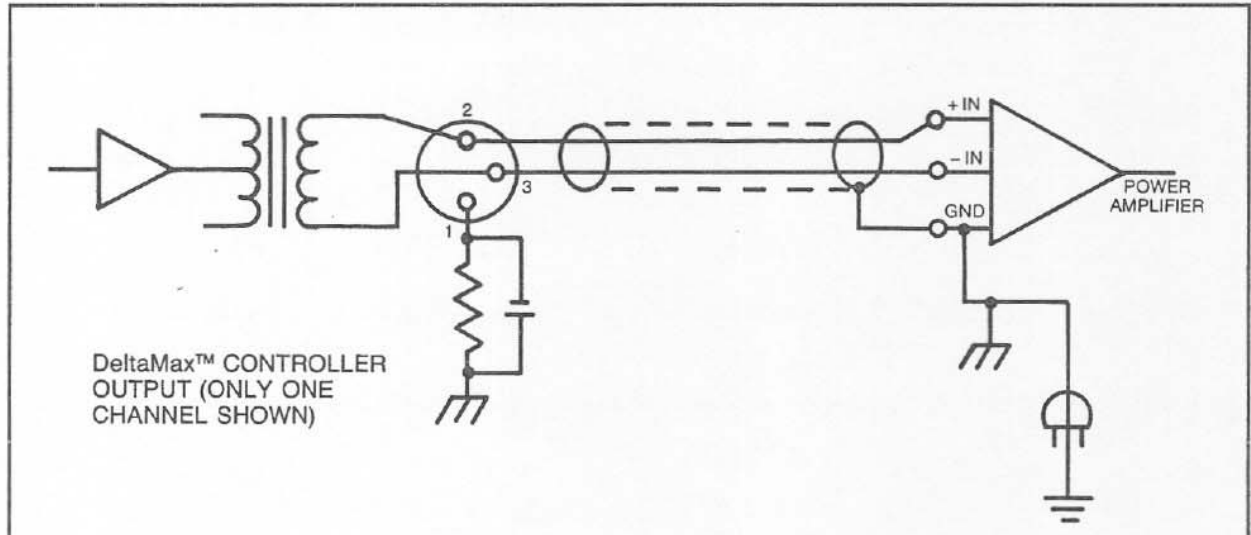


FIGURE 7 - DeltaMax™ Output Connection

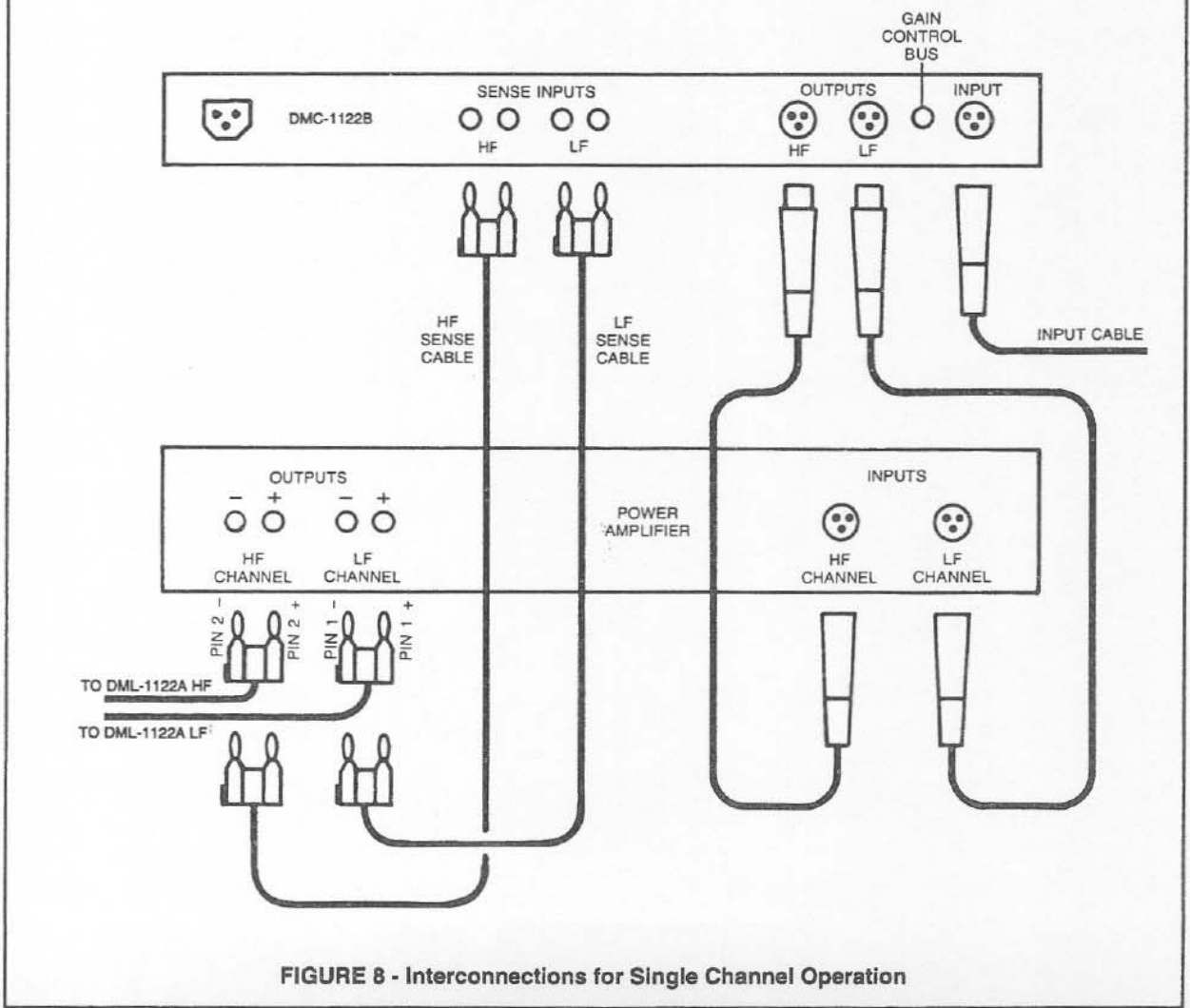


FIGURE 8 - Interconnections for Single Channel Operation

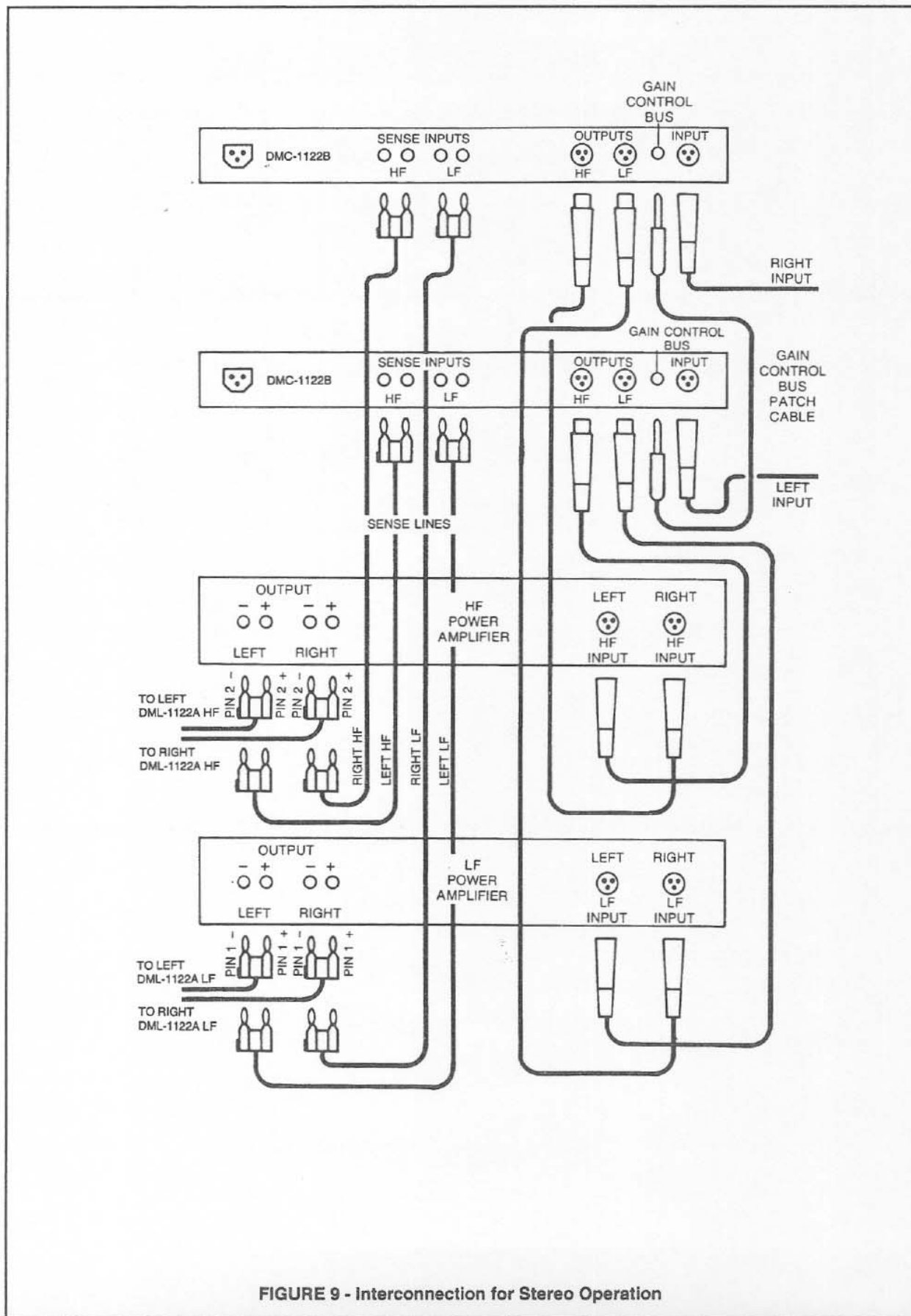
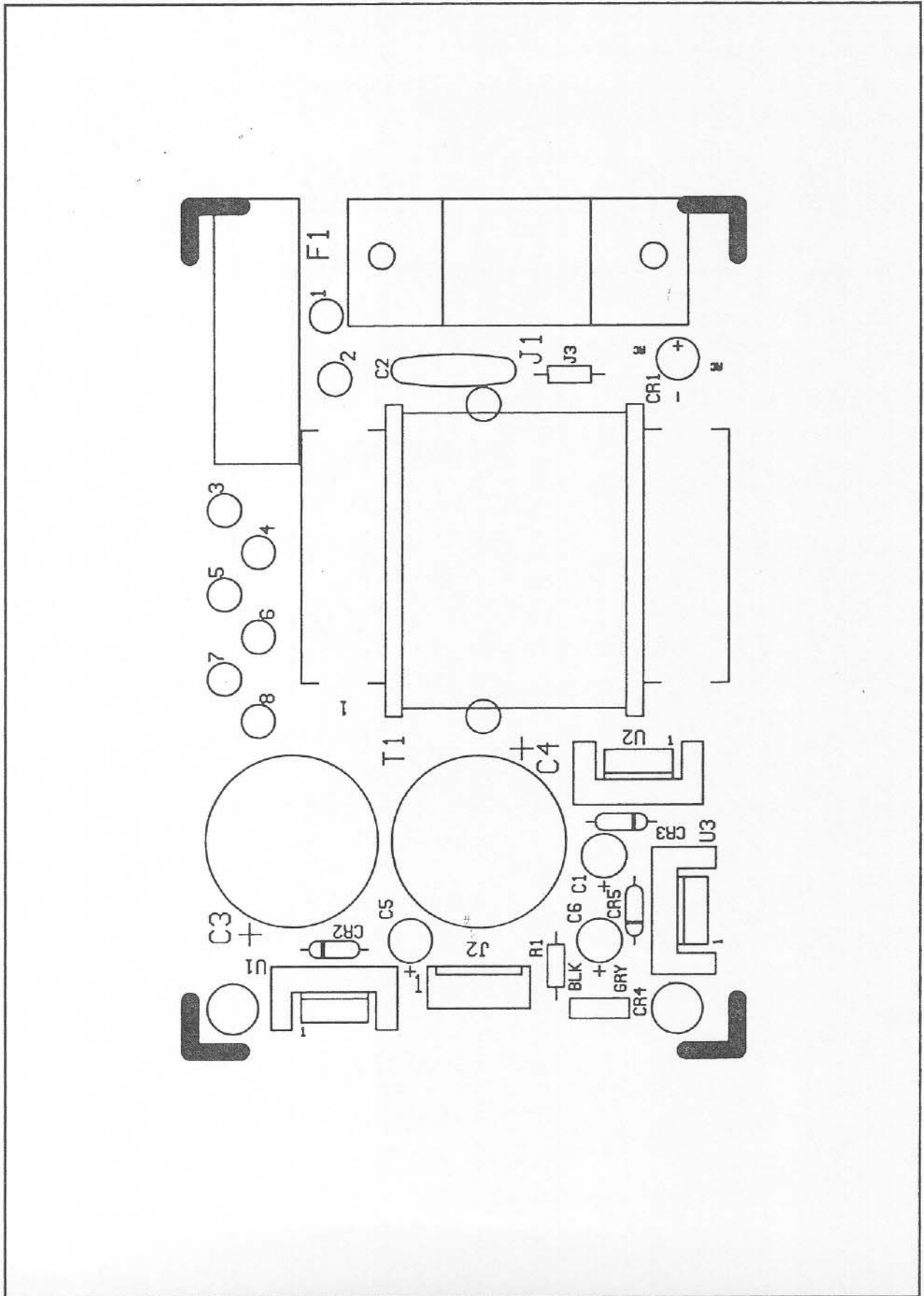
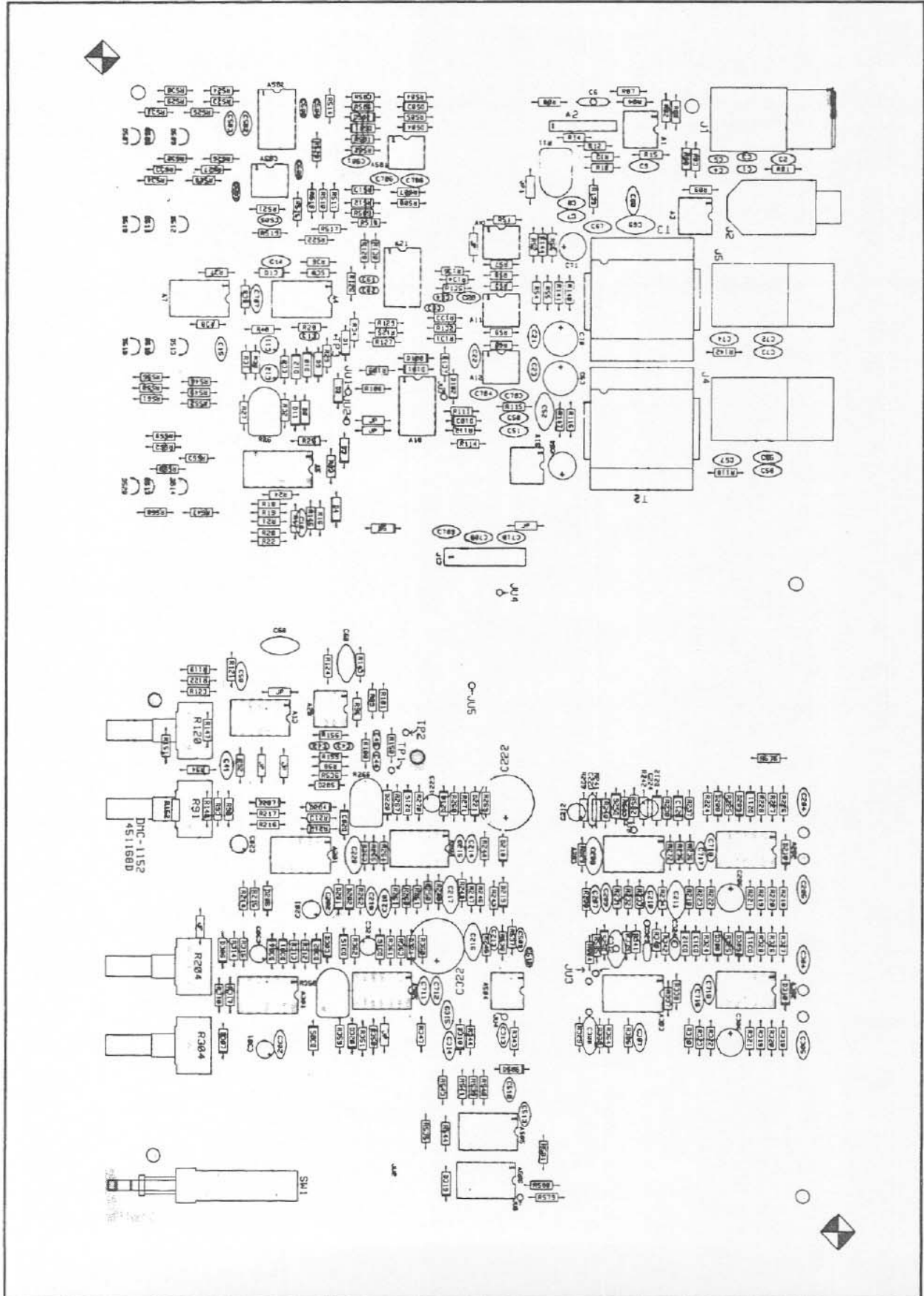


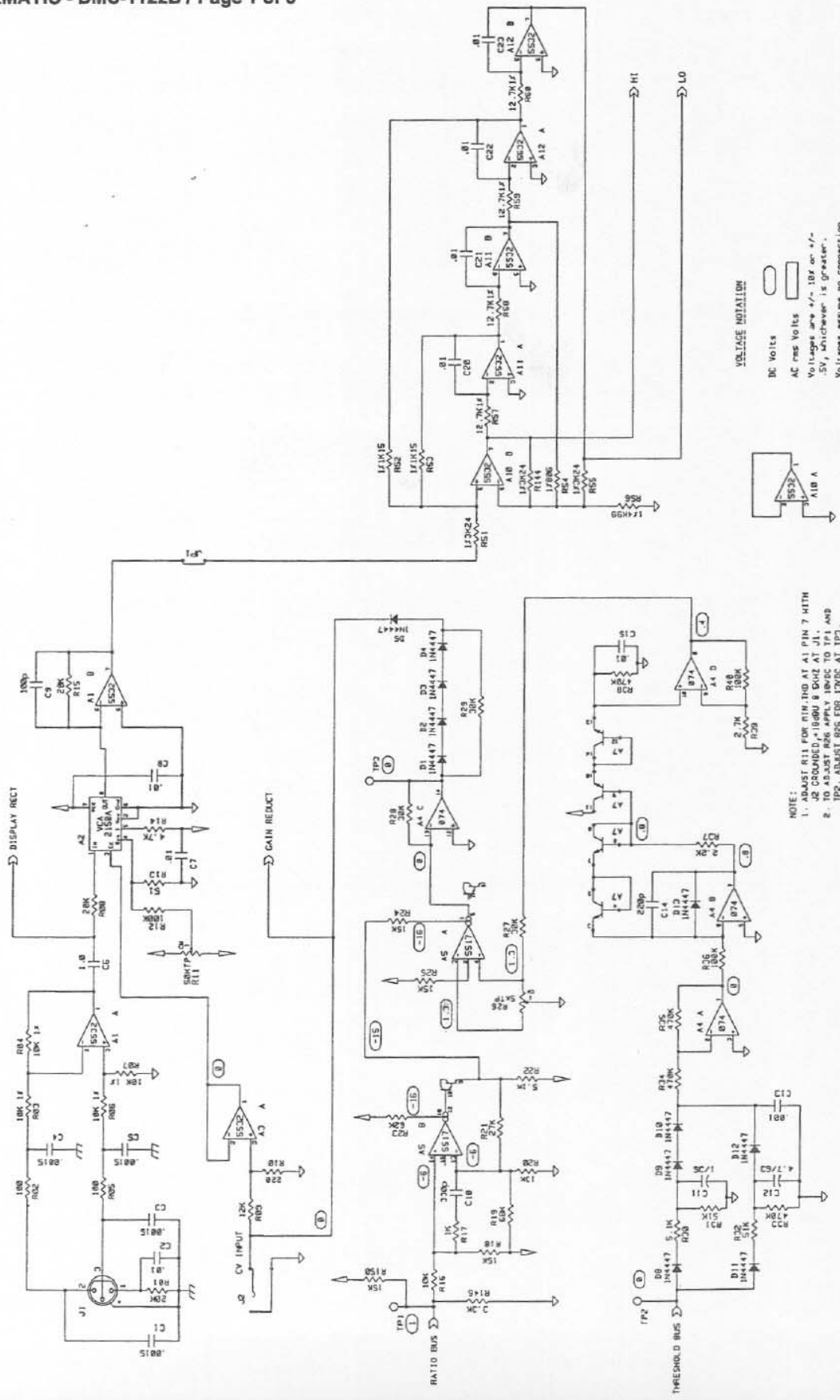
FIGURE 9 - Interconnection for Stereo Operation

POWER SUPPLY P.C. BOARD



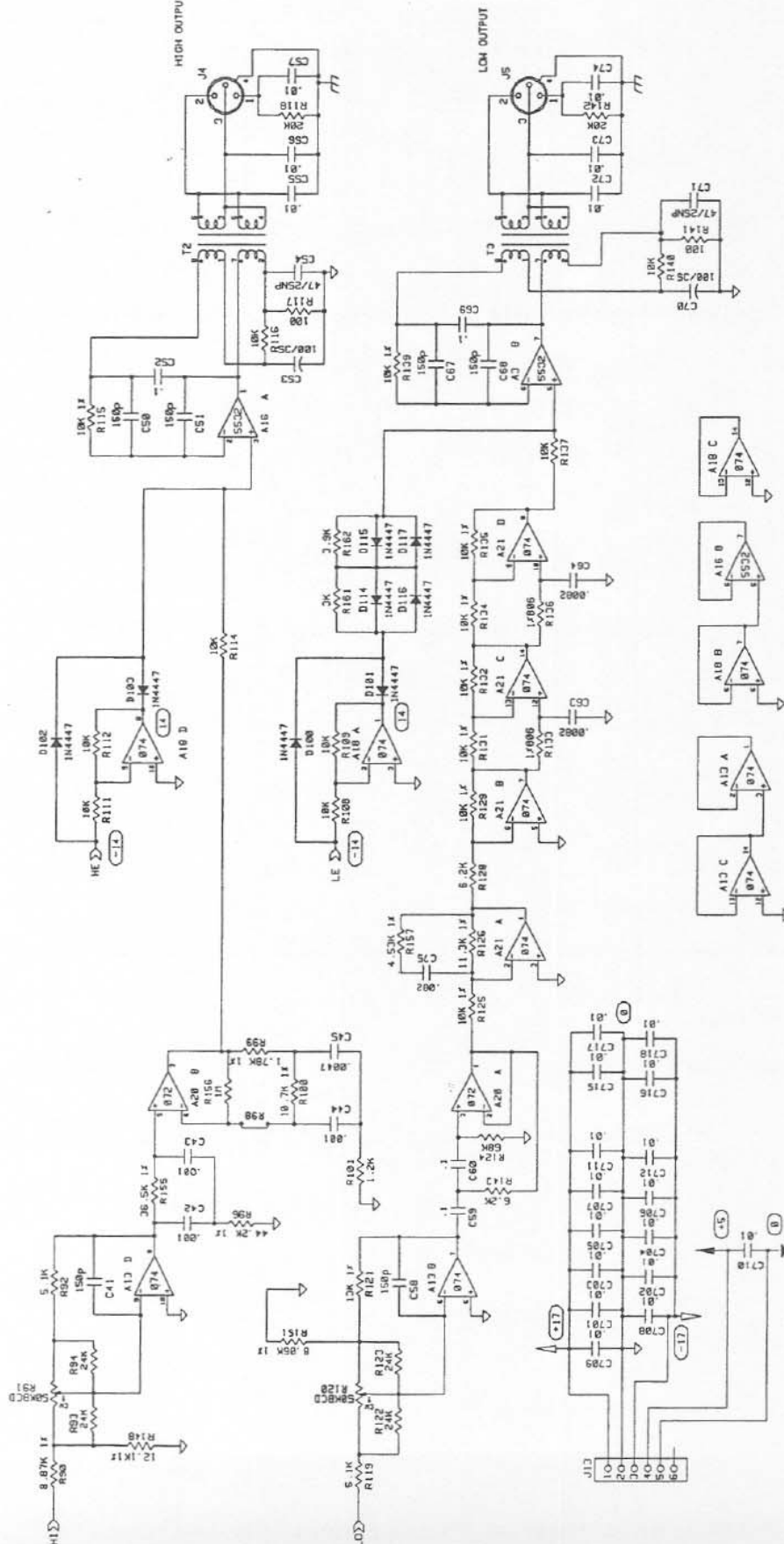
MAIN P.C. BOARD

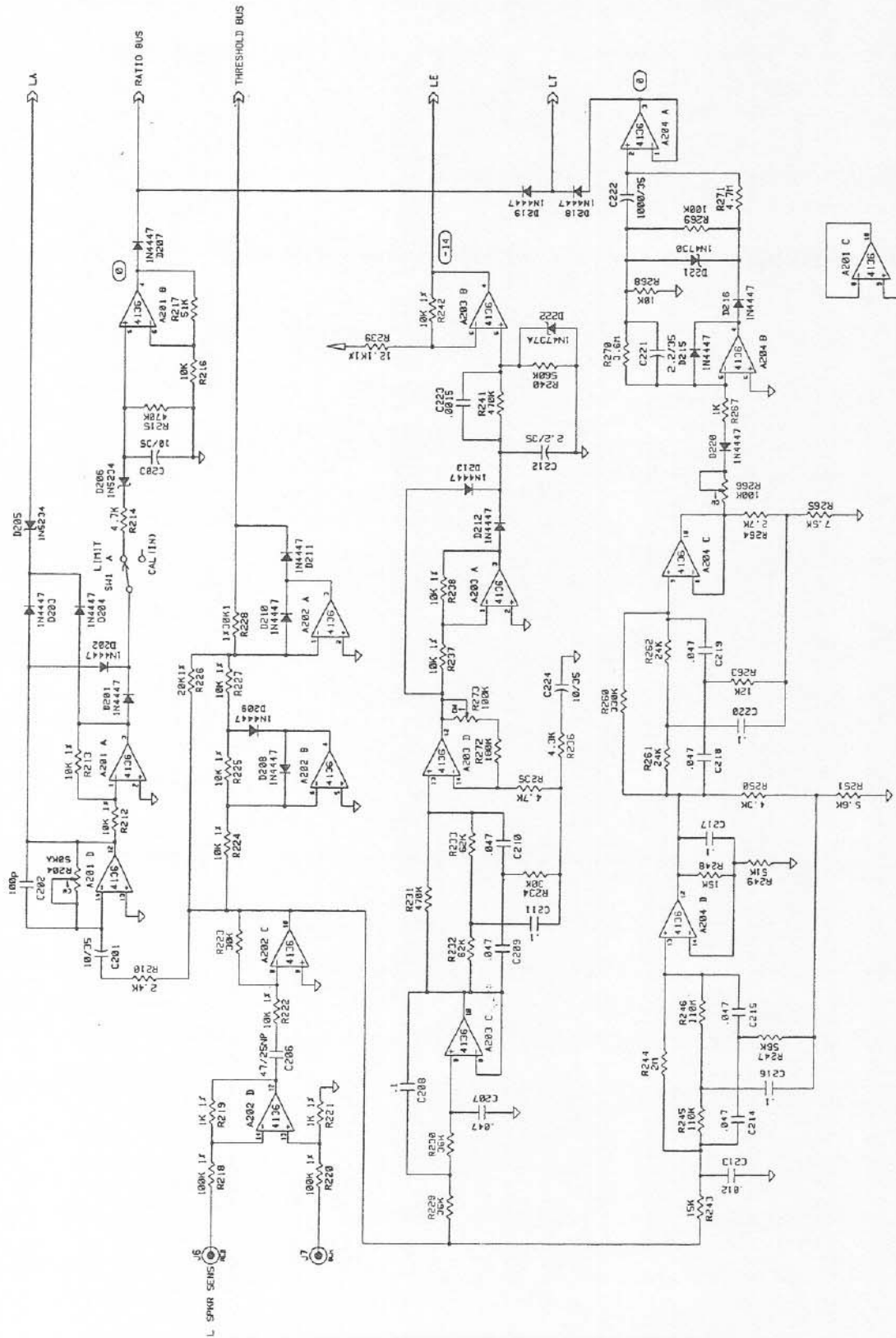




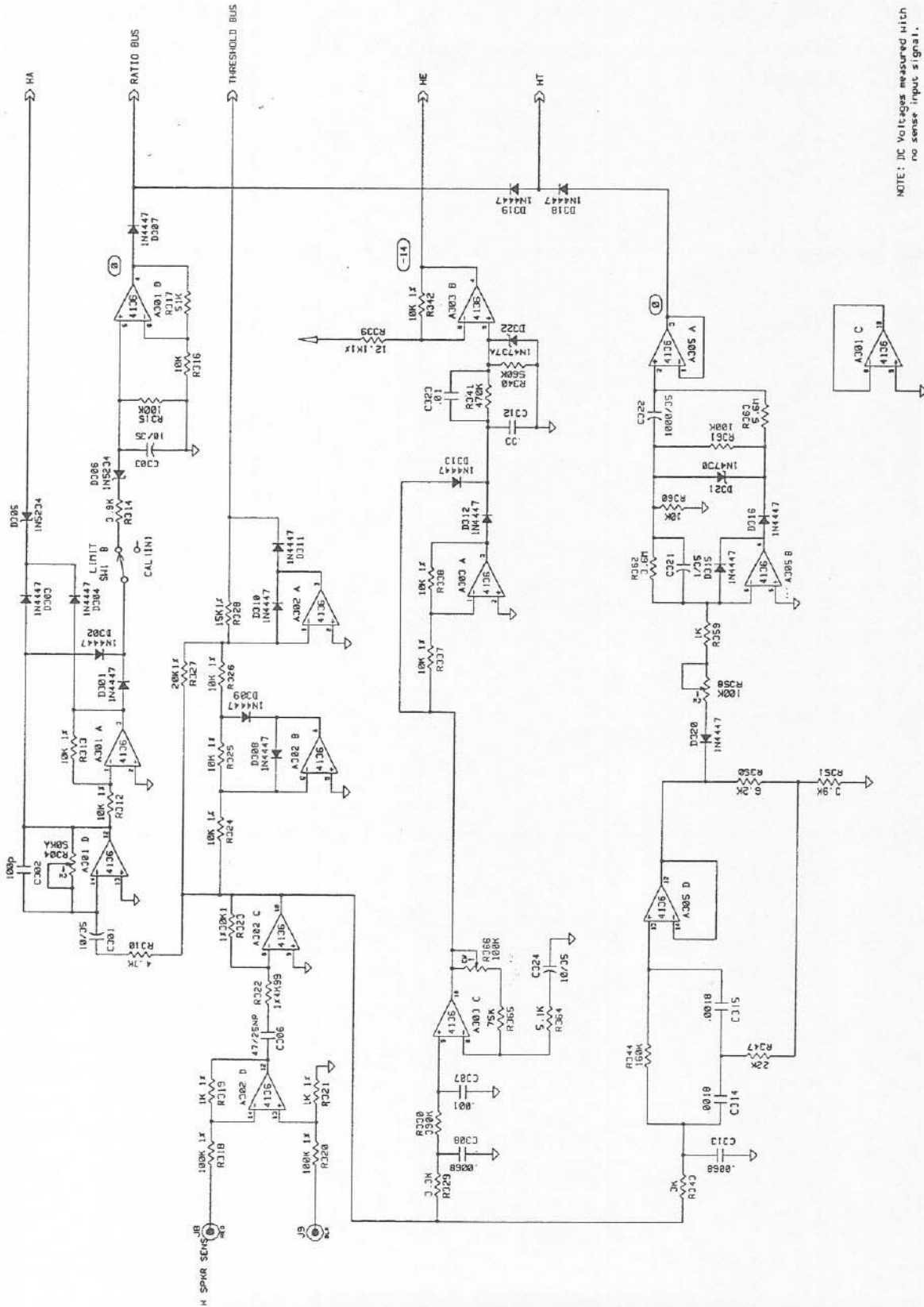


SCHEMATIC - DMC-1122B / Page 2 of 6



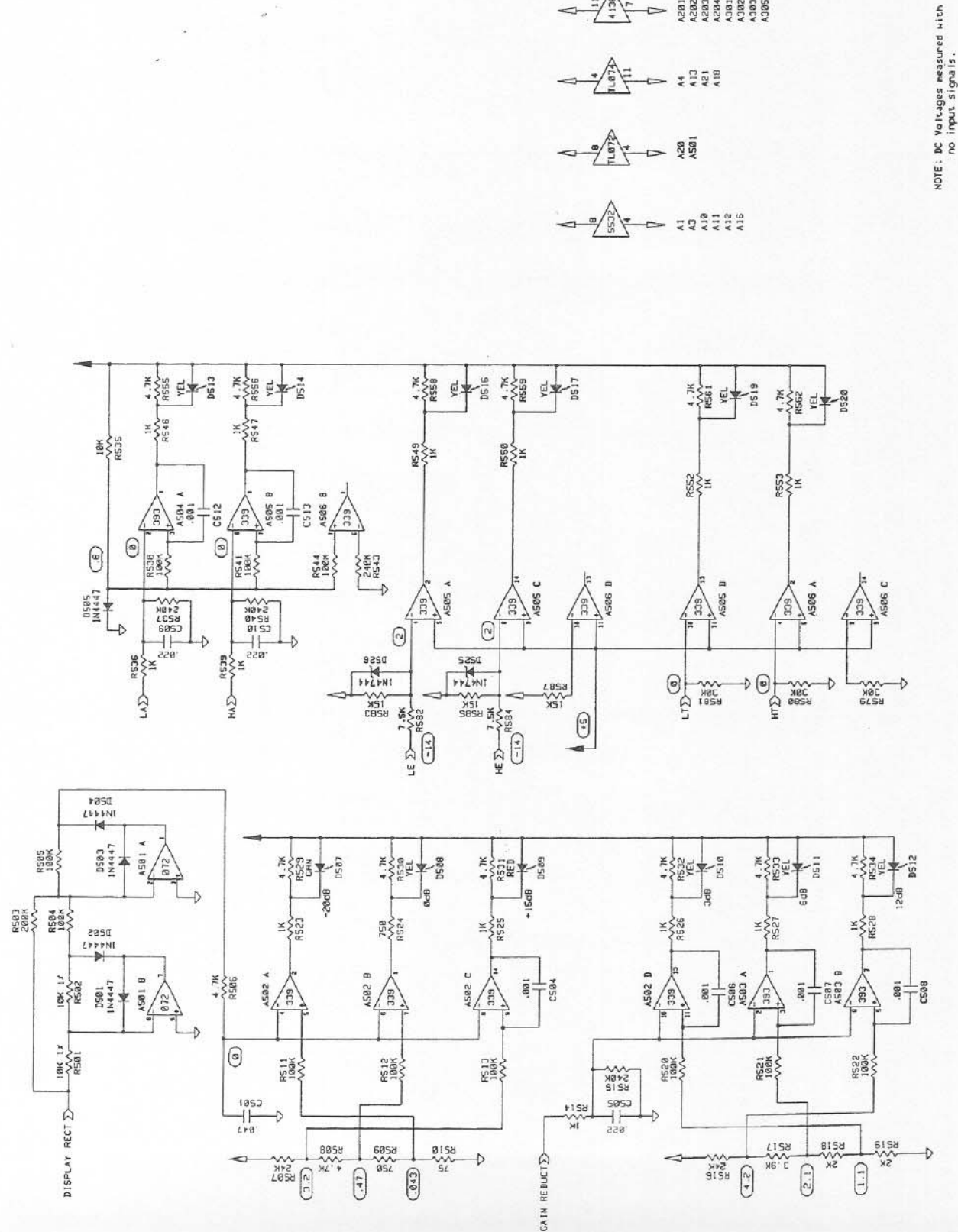


NOTE: DC Voltages measured with no sense input signal.

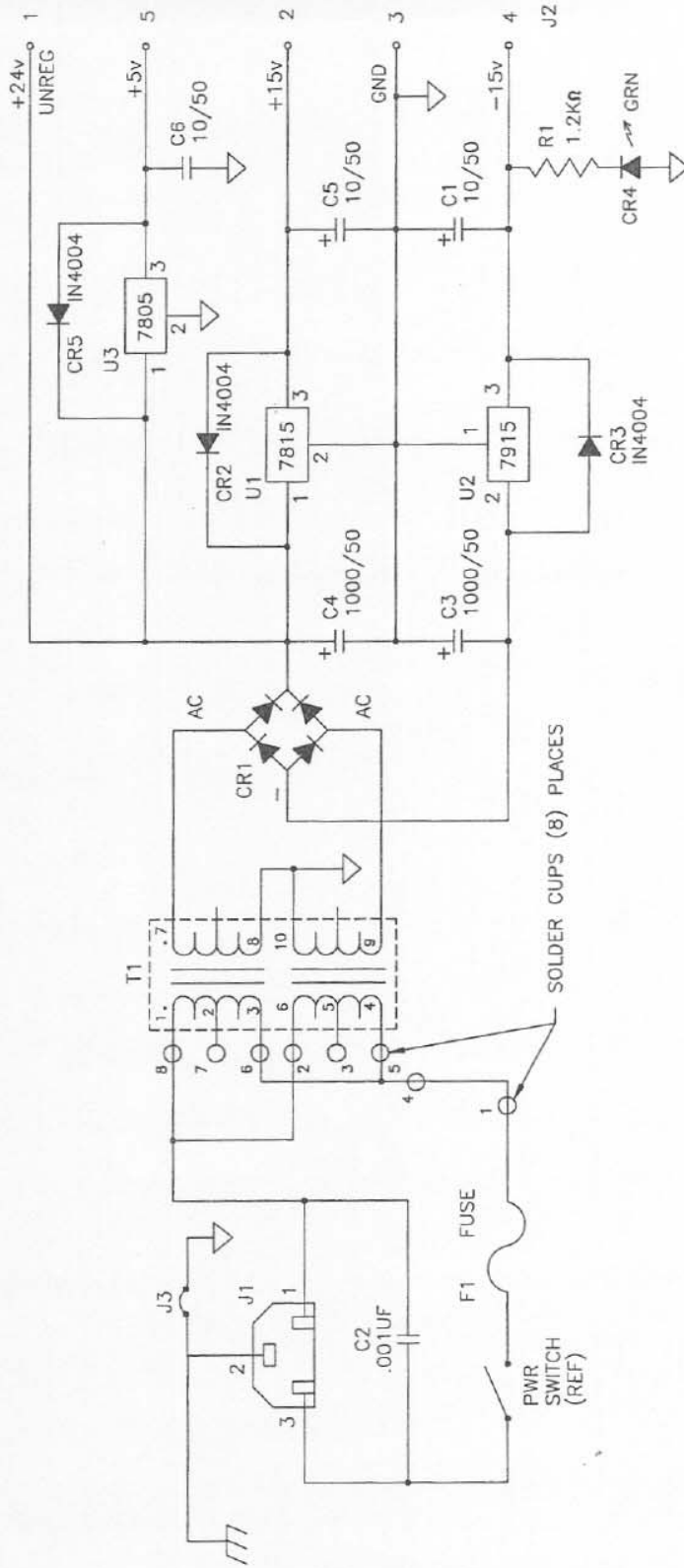


NOTE: IC Voltages measured with no sense input signal.

SCHEMATIC - DMC-1122B / Page 5 of 6



NOTE: DC Voltages measured with no input signals.



**SERVICE/WARRANTY INFORMATION****SHIPPING DAMAGE**

Inspect the shipping carton for possible damage. If damage is found, notify the transportation company immediately. Save the carton as evidence for the carrier to inspect. If damage occurs during shipping, it is the responsibility of the consignee to file a claim with the carrier. If the carton is in good condition but the unit is damaged, call Electro-Voice.

Included in the box with the DeltaMax™ Controller is a power cord, warranty card, two operating voltage labels, a 1/10 amp fuse for 220-240 V ac, and this manual.

**FIELD SERVICE****Controller Power Inspection**

If the DMC power indicator does not light:

1. Check the power switch.
2. Check the line cord.
3. Check the fuse.
4. Check the mains voltage and DMC operating voltage configuration.

**SERVICING THE SPEAKER SYSTEM**

The DML-1122A was designed for expedient field service. The foam grille may be removed by simply grabbing a corner and gently peeling it off. Once the screws securing the steel grille are removed (using a #2 Phillips screwdriver), the grille may be lifted off. Loosening the four woofer clamp bolts (using a straight-blade screwdriver, or a 3/8-inch nutdriver or socket wrench) allows the woofer to be easily removed. Once the horn-mounting screws are removed (using a #2 Phillips screwdriver), the compression driver may be accessed through both the horn and woofer cutouts in the baffle board and may be removed from the horn (using a 3/8-inch socket wrench). A woofer failure will require replacement of the entire driver. In the case of compression driver failure, a diaphragm assembly replacement kit with instructions is available; or, if desired, the complete driver may be returned for service.

Listed below are the available driver replacement and/or repair parts as well as a variety of other user serviceable items that are available from the Electro-Voice service department in Buchanan, Michigan:

| Item                    | EV Part Numbers    |  |
|-------------------------|--------------------|--|
|                         | DML-1122AP/1122APF |  |
| Complete woofer         | 812-1372           |  |
| HP driver diaphragm kit | 81147XX            |  |
| Logo nameplate assy.    | 81680              |  |
| Foam grille             | 72711              |  |
| Steel grille assy.      | 81922              |  |
| Input panel sub-assy.   | 81865              |  |
| Connector (NL4MP-R)     | 17305              |  |
| Cable Connector         | 17306              |  |

**WARRANTY (Limited)**

Electro-Voice products are guaranteed against malfunction due to defects in materials or workmanship for a specified period, as noted in the individual product-line statement(s) below, or in the individual product data sheet or owner's manual, beginning with the date of original purchase. If such malfunction occurs during the specified period, the product will be repaired or replaced (at our option) without charge. The product will be returned to the customer prepaid. **Exclusions and Limitations:** The Limited Warranty does not apply to: (a) exterior finish or appearance; (b) certain specific items described in the individual product-line statement(s) below, or in the individual product data sheet or owner's manual; (c) malfunction resulting from use or operation of the product other than as specified in the product data sheet or owner's manual; (d) malfunction resulting from misuse or abuse of the product; or (e) malfunction occurring at any time after repairs have been made to the product by anyone other than Electro-Voice or any of its authorized service representatives. **Obtaining Warranty Service:** To obtain warranty service, a customer must deliver the product, prepaid, to Electro-Voice or any of its authorized service representatives together with proof of purchase of the product in the form of a bill of sale or receipted invoice. A list of authorized service representatives is available from Electro-Voice at 600 Cecil Street, Buchanan, MI 49107 (616/695-6831 or 800/234-6831) and/or Electro-Voice West, at 8234 Doe Avenue, Visalia, CA 93291 (209/651-7777 or 800/825-1242). **Incidental and Consequential Damages Excluded:** Product repair or replacement and return to the customer are the only remedies provided to the customer. Electro-Voice shall not be liable for any incidental or consequential damages including, without limitation, injury to persons or property or loss of use. Some states do not allow the exclusion or limitation of incidental or consequential damages so the above limitation or exclusion may not apply to you. **Other Rights:** This warranty gives you specific legal rights, and you may also have other rights which vary from state to state.

**Electro-Voice Speakers and Speaker Systems** are guaranteed against malfunction due to defects in materials or workmanship for a period of five (5) years from the date of original purchase. The Limited Warranty does not apply to burned voice coils or malfunctions such as cone and/or coil damage resulting from improperly designed enclosures.

**Electro-Voice Electronics** are guaranteed against malfunction due to defects in materials or workmanship for a period of three (3) years from the date of original purchase. **Electro-Voice Flying Hardware** (including enclosure-mounted hardware and rigging accessories) is guaranteed against malfunction due to defects in materials or workmanship for a period of one (1) year from the date of original purchase. Additional details are included in the Uniform Limited Warranty statement.

Service and repair address for this product: Electro-Voice, Inc., 600 Cecil Street, Buchanan, Michigan 49107 (616/695-6831 or 800/234-6831).

Specifications subject to change without notice.

## DMC-1122B REPAIR PARTS LIST

## Power Supply Board Assembly (27-01-038256)

|               |              |  |
|---------------|--------------|--|
| C1,C5,C6      | 15-01-124502 | Capacitor, 10uf, 50 volt, aluminum electrolytic, Radial Lead   |
| C3,C4         | 15-01-124505 | Capacitor, 1000uf, 50 volt, aluminum electrolytic, Radial Lead |
| C2            | 15-02-026884 | Capacitor, 0.01uf, 250 volt, ceramic, UL approved              |
| U1            | 17-01-121660 | I.C., voltage regulator, +15V, LM7815                          |
| U2            | 17-01-121659 | I.C., voltage regulator, -15V, LM7915                          |
| U3            | 17-01-119087 | I.C., voltage regulator, +5V, LM7805                           |
| CR1           | 48-02-037580 | Bridge Rectifier, 1.5 amp, pc mount                            |
| CR2, CR3, CR5 | 48-02-042787 | Diode, 1N4004, 400V, 1A  |
| CR4           | 39-01-124973 | LED, green   |
| F1            | 51-04-124634 | Fuse, 175mA, 250V, slow blow                                   |
| T1            | 56-08-025906 | Transformer, power, pc mount                                   |

## DMC-1122B Main Board Assembly (27-01-028359)

|                                   |              |   |
|-----------------------------------|--------------|---|
| C53,C70                           | 15-01-027316 | Capacitor, 100uf, 35V, aluminum electrolytic  |
| C222,C322                         | 15-01-027317 | Capacitor, 1000uf, 35V, aluminum electrolytic |
| C206,C306,C54,<br>C71             | 15-01-027327 | Capacitor, 47uf, 25V, aluminum electrolytic   |
| C12                               | 15-01-028703 | Capacitor, 4.7uf, 63V, aluminum electrolytic  |
| C6,C11,C321                       | 15-01-028850 | Capacitor, 1uf, 35V, aluminum electrolytic    |
| C212,C221                         | 15-01-028851 | Capacitor, 2.2uf, 35V, aluminum electrolytic  |
| C201,C203,C224,<br>C301,C303,C324 | 15-01-122935 | Capacitor, 10uf, 35V, aluminum electrolytic   |
| C14                               | 15-01-026831 | Capacitor, 220pf, 50V, ceramic                |
| C41,C50,C51,C58<br>C67,C68        | 15-02-027325 | Capacitor, 150pf, 100V, ceramic               |
| C1,C3,C4,C5                       | 15-02-027326 | Capacitor, 1500pf, 100V, ceramic              |
| C9,C202,C203                      | 15-02-027455 | Capacitor, 100pf, 50V, ceramic                |
| C10                               | 15-02-028803 | Capacitor, 330pf, 50V, ceramic                |

|   |              |   |
|---|--------------|---|
| C2,C7,C8,C55,C56,<br>C57,C72,C73,C74<br>C701,C702,C703,<br>C704,C705,C706,<br>C707,C708,C709,<br>C710,C711,C712,<br>C713,C714,C715,<br>C716,C717,C718 | 15-02-100307 | Capacitor, 0.01uf, 100V, Z5U ceramic      |
| C52,C59,C60,C69,<br>C208,C211,C216,<br>C217,C220  | 15-06-026822 | Capacitor, 0.1uf, 50V, 5%, mylar          |
| C13,C42,C43,C44,<br>C307,C504,C506,<br>C507,C508,C512,<br>C513  | 15-06-026823 | Capacitor, 0.001uf, 50V, 5%, mylar        |
| C45   | 15-06-026824 | Capacitor, 0.0047uf, 50V, 5%, mylar       |
| C213  | 15-06-026825 | Capacitor, 0.012uf, 50V, 5%, mylar        |
| C223  | 15-06-027320 | Capacitor, 0.0015uf, 50V, 5%, mylar       |
| C63,C64   | 15-06-027321 | Capacitor, 0.0082uf, 50V, 5%, mylar       |
| C15,C20,C21,C22<br>C23,C323   | 15-06-027322 | Capacitor, 0.01uf, 50V, 5%, mylar         |
| C207,C209,C210,<br>C214,C215,C218,<br>C219,C501   | 15-06-027367 | Capacitor, 0.047uf, 50V, 5%, mylar        |
| C505,C509,C510  | 15-06-028020 | Capacitor, 0.022uf, 50V, 10%, mylar       |
| C312  | 15-06-028155 | Capacitor, 0.33uf, 50V, 5%, mylar         |
| C314,C315   | 15-06-028852 | Capacitor, 0.0018uf, 50V, 10%, mylar      |
| C308,C313   | 15-06-028853 | Capacitor, 0.0068uf, 50V, 10%, mylar      |
| A201,A202,A203,<br>A204,A301,A302,<br>A303,A305   | 17-01-027338 | I.C., RC4136                              |
| A502,A505,A506  | 17-01-028867 | I.C., LM339                               |
| A503,A504   | 17-01-028902 | I.C., LM393P                              |
| A2  | 17-01-028905 | I.C., dbx2150A                            |
| A7  | 17-01-028906 | I.C., CA3046                              |
| A5  | 17-01-028907 | I.C., NE5517N                             |
| A1,A3,A10,A11,<br>A12,A16   | 17-01-122832 | I.C., NE5523A                             |
| A4,A13,A18,A21  | 17-01-124461 | I.C., TL074CN                             |
| A20,A501  | 17-01-124688 | I.C., TL072CP                             |
| J2  | 21-01-028908 | Connector, ¼ inch phono jack, right angle |
| J1  | 21-01-124470 | Connector, XLR, female, right angle       |

|  |              |                                   |  |
|--|--------------|-----------------------------------|--|
| J4,J5  | 21-01-124642 | Connector, XLR, male, right angle |  |
| D507   | 39-01-028846 | LED, green                        |  |
| D509   | 39-01-028893 | LED, red                          |  |
| D508,D510,D511,<br>D512,D513,D514,<br>D516,D517,D519,<br>D520  | 39-01-028894 | LED, yellow                       |  |
| R271   | 47-01-027332 | Resistor, 4.7K, 5%, ¼W            |  |
| R236,R250  | 47-01-027461 | Resistor, 4.3K, 5%, ¼W            |  |
| R13  | 47-01-028860 | Resistor, 51, 5%, ¼W              |  |
| R244   | 47-01-028862 | Resistor, 2M, 5%, ¼W              |  |
| R270,R362  | 47-01-028865 | Resistor, 3.6M, 5%, ¼W            |  |
| R510   | 47-01-102051 | Resistor, 75, 5%, ¼W              |  |
| R2,R5,R117,R141  | 47-01-102054 | Resistor, 100, 5%, ¼W             |  |
| R10  | 47-01-102062 | Resistor, 220, 5%, ¼W             |  |
| R509,R524  | 47-01-102075 | Resistor, 750, 5%, ¼W             |  |
| R17,R267,R359,R514<br>R523,R525,R526,<br>R527,R528,R536,<br>R539,R546,R547,<br>R549,R550,R552,<br>R553   | 47-01-102078 | Resistor, 1K, 5%, ¼W              |  |
| R101   | 47-01-102080 | Resistor, 1.2K, 5%, ¼W            |  |
| R518,R519  | 47-01-102085 | Resistor, 2K, 5%, ¼W              |  |
| R37  | 47-01-102086 | Resistor, 2.2K, 5%, ¼W            |  |
| R210   | 47-01-102087 | Resistor, 2.4K, 5%, ¼W            |  |
| R39,R264   | 47-01-102088 | Resistor, 2.7K, 5%, ¼W            |  |
| R161,R343  | 47-01-102089 | Resistor, 3K, 5%, ¼W              |  |
| R146,R329  | 47-01-102090 | Resistor, 3.3K, 5%, ¼W            |  |
| R162,R314,R351,<br>R517  | 47-01-102092 | Resistor, 3.9K, 5%, ¼W            |  |
| R14,R214,R235,<br>R310,R506,R508,<br>R529,R530,R531,<br>R532,R533,R534,<br>R555,R556,R558,<br>R559,R561,R562   | 47-01-102094 | Resistor, 4.7K, 5%, ¼W            |  |
| R22,R30,R92,<br>R119,R364  | 47-01-102095 | Resistor, 5.1K, 5%, ¼W            |  |
| R251   | 47-01-102096 | Resistor, 5.6K, 5%, ¼W            |  |
| R128,R143,R350   | 47-01-102097 | Resistor, 6.2K, 5%, ¼W            |  |
| R265,R582,R584   | 47-01-102099 | Resistor, 7.5K, 5%, ¼W            |  |
| R16,R108,R109,R111,<br>R112,R114,R116,<br>R137,R140,R216,<br>R268,R316,R361,<br>R535   | 47-01-102102 | Resistor, 10K, 5%, ¼W             |  |
| R9,R263  | 47-01-102104 | Resistor, 12K, 5%, ¼W             |  |
| R20  | 47-01-102105 | Resistor, 13K, 5%, ¼W             |  |
| R18,R24,R150,<br>243,R248,R583,<br>R585,R587   | 47-01-102106 | Resistor, 15K, 5%, ¼W             |  |
| R1,R8,R15,R118,<br>R142  | 47-01-102109 | Resistor, 20K, 5%, ¼W             |  |
| R347   | 47-01-102110 | Resistor, 22K, 5%, ¼W             |  |
| R93,R94,R122,<br>R123,R261,R262,<br>R507,R516  | 47-01-102111 | Resistor, 24K, 5%, ¼W             |  |
| R21  | 47-01-102112 | Resistor, 27K, 5%, ¼W             |  |
| R27,R28,R29,<br>R223,R234,R579,<br>R580,R581   | 47-01-102113 | Resistor, 30K, 5%, ¼W             |  |
| R229,R230,R262   | 47-01-102115 | Resistor, 36K, 5%, ¼W             |  |
| R31,R32,R217,<br>R249,R317   | 47-01-102120 | Resistor, 51K, 5%, ¼W             |  |
| R247   | 47-01-102121 | Resistor, 56K, 5%, ¼W             |  |
| R23,R232,R233  | 47-01-102122 | Resistor, 62K, 5%, ¼W             |  |
| R19,R124   | 47-01-102123 | Resistor, 68K, 5%, ¼W             |  |
| R365   | 47-01-102124 | Resistor, 75K, 5%, ¼W             |  |
| R12,R36,R40,R269,<br>R315,R360,R504,<br>R505,R511,R512,<br>R513,R520,R521,<br>R522,R538,R541,<br>R544  | 47-01-102127 | Resistor, 100K, 5%, ¼W            |  |
| R245,R246  | 47-01-102128 | Resistor, 110K, 5%, ¼W            |  |
| R344   | 47-01-102132 | Resistor, 160K, 5%, ¼W            |  |
| R330   | 47-01-102886 | Resistor, 390K, 5%, ¼W            |  |
| R260   | 47-01-104541 | Resistor, 330K, 5%, ¼W            |  |
| R537,R540,R543   | 47-01-108441 | Resistor, 240K, 5%, ¼W            |  |
| R156   | 47-01-108491 | Resistor, 1M, 5%, ¼W              |  |
| R33,R34,R35,R38,<br>R215,R231,R241,<br>R341  | 47-01-109204 | Resistor, 470K, 5%, ¼W            |  |
| R272   | 47-01-109298 | Resistor, 180K, 5%, ¼W            |  |
| R503   | 47-01-112203 | Resistor, 200K, 5%, ¼W            |  |
| R363   | 47-01-113206 | Resistor, 5.6M, 5%, ¼W            |  |
| R54,R133,R136  | 47-03-027328 | Resistor, 806, 1%, ¼W             |  |
| R96  | 47-03-027331 | Resistor, 44.2K, 1%, ¼W           |  |
| R157   | 47-03-028159 | Resistor, 4.53K, 1%, ¼W           |  |
| R57,R58,R59,R60  | 47-03-028214 | Resistor, 12.7K, 1%, ¼W           |  |
| R151   | 47-03-028857 | Resistor, 8.06K, 1%, ¼W           |  |
| R240,R340  | 47-03-038218 | Resistor, 536K, 1%, ¼W            |  |
| R155   | 47-03-109431 | Resistor, 36.5K, 1%, ¼W           |  |
| R226,R327  | 47-03-109434 | Resistor, 20.0K, 1%, ¼W           |  |
| R3,R4,R6,R7,<br>R115,R125,R129,<br>R131,R132,R134,<br>R135,R139,R212,<br>R213,R222,R224,<br>R225,R227,R237,<br>R238,R242,R312,<br>R313,R324,R325,<br>R326,R337,R338,<br>R342,R501,R502 | 47-03-119305 | Resistor, 10.0K, 1%, ¼W           |  |
| R218,R220,R318,<br>R320  | 47-03-119305 | Resistor, 100K, 1%, ¼W            |  |
| R219,R221,R319,<br>R321  | 47-03-121532 | Resistor, 1.00K, 1%, ¼W           |  |
| R515   | 47-03-121651 | Resistor, 14.7K, 1%, ¼W           |  |
| R100   | 47-03-121737 | Resistor, 10.7K, 1%, ¼W           |  |
| R121   | 47-03-123010 | Resistor, 13.0K, 1%, ¼W           |  |
| R328   | 47-03-124484 | Resistor, 15.0K, 1%, ¼W           |  |
| R228,R323  | 47-03-124615 | Resistor, 30.1K, 1%, ¼W           |  |
| R99  | 47-03-124648 | Resistor, 1.78K, 1%, ¼W           |  |
| R90  | 47-03-124654 | Resistor, 8.87K, 1%, ¼W           |  |
| R126,R239,R339   | 47-03-124655 | Resistor, 11.3K, 1%, ¼W           |  |
| R148   | 47-03-124685 | Resistor, 12.1K, 1%, ¼W           |  |



|   |              |   |
|---|--------------|---|
| R56,R322  | 47-03-124696 | Resistor, 4.99K, 1%, ¼W                         |
| R51,R55,R144  | 47-03-124697 | Resistor, 3.24K, 1%, ¼W                         |
| R52,R53   | 47-03-124699 | Resistor, 1.15K, 1%, ¼W                         |
| R120,R91  | 47-06-027344 | Potentiometer, 50K-B<br>K86, CC, 16mm, vertical |
| R26   | 47-06-027459 | Potentiometer, 5k,<br>trimmer                   |
| R204,R304   | 47-06-028556 | Potentiometer, 50k,<br>16mm, vertical           |
| R11   | 47-06-028818 | Potentiometer, 50k,<br>trimmer                  |
| R266,R273,R358,<br>R366   | 47-06-028910 | Potentiometer, 100k,<br>trimmer                 |
| D1,D2,D3,D4,D5,<br>D8,D9,D10,D11,<br>D12,D13,D100,D101,<br>D102,D103,D114,<br>D115,D116,D117,<br>D201,D202,D203,<br>D204,D207,D208,<br>D209,D210,D211,<br>D212,D213,D215,<br>D216,D218,D219,<br>D220,D301,D302,<br>D303,D304,D307,<br>D308,D309,D310,<br>D311,D312,D313,<br>D315,D316,D318,<br>D319,D320,D501,<br>D502,D503,D504,<br>D505 | 48-01-027340 | Diode, Signal, 1N4447                           |
| D205,D206,D305,D306   | 48-01-028163 | Diode, Zener, 6.2V, 1N5234                      |
| D525,D526   | 48-01-028891 | Diode, Zener, 15V,<br>1N4744                    |
| D222,D322   | 48-01-028892 | Diode, Zener, 7.5V,<br>1N4737A                  |
| D221,D321   | 48-01-028896 | Diode, Zener, 3.9V,<br>1N4730A                  |
| SW1   | 51-02-028058 | Switch, push ON/push<br>OFF                     |
| T2,T3   | 56-07-026392 | transformer, audio<br>output                    |